

Central Seam Plus[®]

Installation Guide

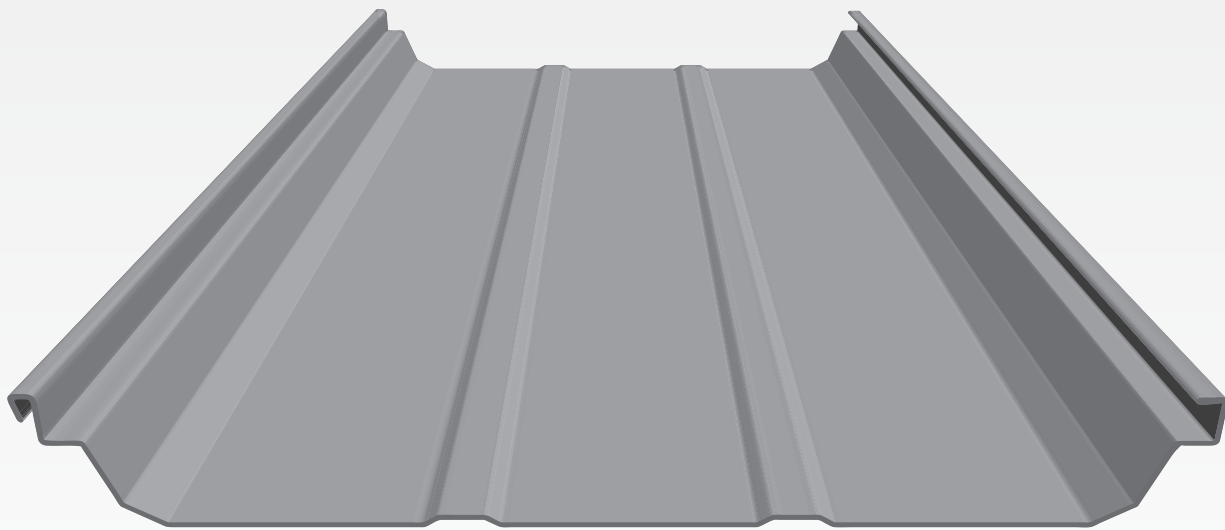

OUR MISSION

The men and women at Central States Manufacturing, Inc. would like to welcome you.

Central States Manufacturing, Inc. is a **100% employee-owned** company devoted to the **personal growth and well-being** of our owners. We are dedicated to **increasing the value of our company** by **making Raving Fans** of our customers through **exceeding their expectations**, being **easy to do business with**, demonstrating **excellence** in all aspects of our business and being committed to **improving their business**.

It is our promise to maintain **honesty and integrity** with everyone our lives may touch. With thanksgiving for the blessings we have been given, we are committed to **servicing the communities** where we live and work by giving back a portion of our time, talents and profits.



Right.
On Time.
Every Time.®

INDEX

GENERAL INFORMATION.....	5-8
ERECTION SEQUENCE	
Step 1 — Rake Support	9
Step 2 — Eave	10-13
Step 3 — Thermal Spacer (for high systems only)	14
Step 4 — First Panel	15-16
Step 13 - Seaming Panel Sidelaps	25-27
Step 14 - Last Panel Run	28-29
Step 15 — Outside Closure	30
Step 16 — Ridge-Outside Closure/Flashing.....	31
SPECIAL ERECTION TECHNIQUES	
Recommended Erection Practices.....	32-33
Light Transmitting Panel Trim Installation.....	34
Ridge Ventilator Installation.....	35-42
Vented Ridge	43-44
Mid-Slope Fixed Condition	45
Roof Curb Installation	46-53
Guidelines For Installing Repair Cap on Damaged Seams	54
TRIM DETAILS	
Eave To Endlap.....	55
Ridge	56-57
Expansion Ridge Flashing Lap.....	58
Ridge Flashing Lap.....	59
Standard Gutter Expansion Lap Detail.....	60
Expansion End Cap Assembly	61
Expansion Ridge End Cap	62
Floating Peak Box	63
Rake	64
Rake To Rake	65
Rake Parapet.....	66
High Eave Parapet	67
Eave	68
Snow Gutter	69
10" Deep Gutter - Fixed Eave	70
10" Deep Gutter - Expansion Eave	71
Floating Hip.....	72
Valley	73

IMPORTANT INFORMATION

Descriptions and specifications contained herein were in effect at the time this publication was approved for printing. In a continuing effort to refine and improve products, Central States reserves the right to discontinue products at any time or change specifications and/or designs without incurring obligation. To insure you have the latest

information available, please inquire or visit our website. Application details in this manual may not be appropriate for all environmental conditions, building designs, or panel profiles. Projects should be engineered to conform to applicable building codes, regulations, and accepted industry practices. Insulation is not shown in these details for clarity.

READ THIS MANUAL COMPLETELY PRIOR TO INSTALLATION.

IF THERE IS A CONFLICT BETWEEN PROJECT ERECTION DRAWINGS PROVIDED OR APPROVED BY CENTRAL STATES AND DETAILS IN THIS MANUAL, PROJECT ERECTION DRAWINGS WILL TAKE PRECEDENCE.



OSHA REGULATIONS

It is the responsibility of the erector to install this roof using safe construction practices that are in compliance with OSHA regulations. The manufacturer is not responsible for the performance of this roof system if it is not installed in accordance with the instructions shown in this manual. Deviations from these instructions and details must be approved in writing by the manufacturer.

BRACING

Diaphragm capabilities and purlin stability are not provided by the Central Seam Plus roof system. Therefore, other bracing may be required.

ROOF PITCH

The minimum recommended slope for the roof system is 1/4 on 12. A slope of less than 1/4 on 12 could cause severe ponding and will void material warranties.

ENGINEERING

Application and design details are for illustration purposes only, and may not be appropriate for all environmental conditions or building designs. Projects should be engineered to conform to applicable building codes, regulations, and accepted industry practices.

LIGHT TRANSMITTING PANELS

Light transmitting panels are not designed or intended to bear the weight of any person walking, stepping, standing or resting on them. THE MANUFACTURER DISCLAIMS ANY WARRANTY OR REPRESENTATION, EXPRESS OR IMPLIED, that any person can safely walk, step, stand or rest on or near these light transmitting panels or that they comply with any OSHA regulation.

PREPARATORY REQUIREMENTS

1. A single pitch eave strut must be used.
2. Make sure a rake angle or an alternate structural flat surface has been installed on top of the purlins to accept the "Rake Support".
3. The walls do not have to be erected before the roof is installed. However, for the purpose of this manual, we have assumed that the wall panels have been installed.
4. All primary and secondary framing must be erected, plumbed and squared with bolts tightened according to accepted building practices.
5. The substructure (eave to ridge) must be on plane with a tolerance of 1/4" in 20' and 3/8" in 40'.
6. Central Seam Plus can be erected on various types of construction. However, for the purpose of this manual, we have assumed that the roof will be installed on a new, pre-engineered metal building.
7. Central Seam Plus roof panels are available in 24", and 18" widths. However, for the purpose of this manual, we have assumed that the roof panels will be 24" wide.
8. It is critical that the purlins or joists at the ridge and endlaps be exactly located as detailed in this manual and that they are straight from rafter to rafter. Any mislocation or bowing of these members can cause the fasteners at the endlaps or outside closures to foul the purlin or the back-up plate to foul the clip as the panels expand and contract.
9. Peak purlin spacing (from the centerline of the building) - 12" (For use with Ridge Flash 213 and 214) or 16" (Use with 156) or a 9" or 12" Ridge vent.
10. For the purpose of this manual, we have assumed that this is a standard roof. If your roof is to be UL 90 rated, see UL 90 requirements in the Central Seam Plus product guide.
11. Read recommended erection practices on pages 32 and 33 before proceeding with roof installation.
12. The manufacturer recommends the use of a screw gun with a speed range of 0 - 2000 RPM to properly install all fasteners referenced in this manual. Tools rated to 4000 RPM should never be used for self drilling fasteners typically supplied with metal building components.
13. Field cutting of the panels should be avoided where possible. If field cutting is required, the panels must be cut with nibblers, snips, or shears to prevent edge rusting. Do not cut the panels with saws, abrasive blades, grinders, or torches.

GENERAL INFORMATION

UNLOADING

Upon receiving material, check shipment against shipping list for shortages and damages. The manufacturer will not be responsible for shortages or damages unless they are noted on the shipping list.

Each bundle should be lifted at its center of gravity. Where possible, bundles should remain banded until final placement on roof. If bundles must be opened, they should be retied before lifting.

When lifting bundles with a crane, a spreader bar and nylon straps should be used. NEVER USE WIRE ROPE OR CHAIN SLINGS. THEY WILL DAMAGE THE PANELS.

When lifting bundles with a forklift, forks must be a minimum of five feet apart. Do not transport open bundles. Drive slowly when crossing rough terrain to prevent panel buckling.

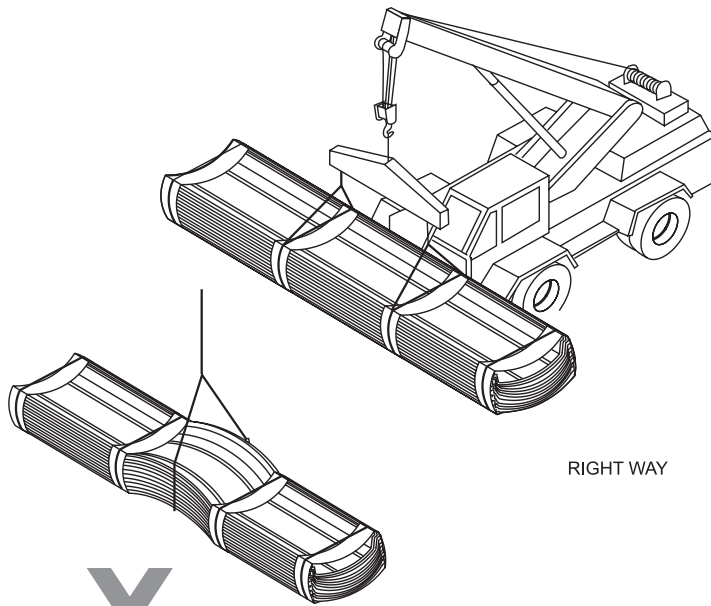

RIGHT WAY

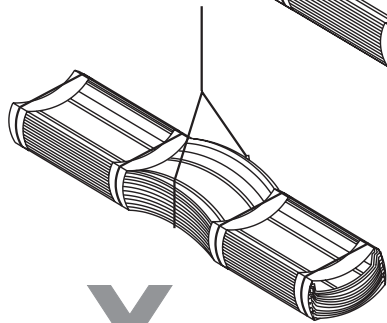

X
WRONG WAY

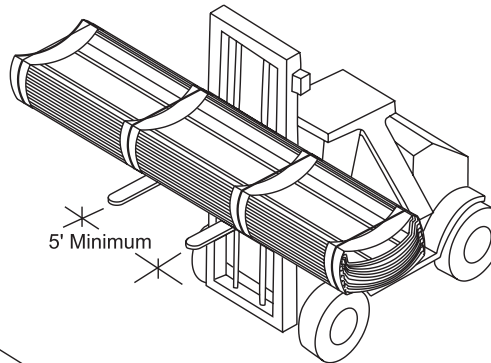

RIGHT WAY

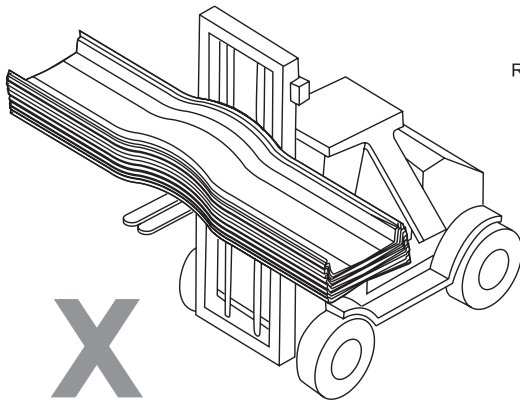

X
WRONG WAY

Improper unloading and handling of bundles and crates may cause bodily injury or material damage. The manufacturer is not responsible for bodily injuries or material damages during unloading and storage.



ROOF PREPARATION

HANDLING/PANEL STORAGE

Standing on one side of the panel, lift it by the seam. If the panel is over 10' long, lift it with two or more people on one side of the panel to prevent buckling. Do not pick panels up by the ends.

Store bundled sheets off the ground sufficiently high enough to allow air circulation beneath bundle and to prevent rising water from entering bundle. Slightly elevate one end of bundle. Prevent rain from entering bundle by covering with tarpaulin, making provision for air circulation between draped edges of tarpaulin and the ground. **PROLONGED STORAGE OF SHEETS IN A BUNDLE IS NOT RECOMMENDED.** If conditions do not permit immediate erection, extra care should be taken to protect sheets from staining or water marks.

Check to see that moisture has not formed inside the bundles during shipment. If moisture is present, panels should be uncrated and wiped dry, then restacked and loosely covered so that air can circulate between the panels.

BAND ONLY

This method is used on all orders, unless otherwise specified by customer. The panels are banded together, causing them to curl up. This enhances the strength of the bundles. Panels bundled in this manner may be handled by a forklift in lengths to 30'. The forklift should have at least 5' between forks. Lengths in excess of 30' must be lifted utilizing a spreader bar. Special care must be given during handling to avoid damage to the locking edges of the panels.

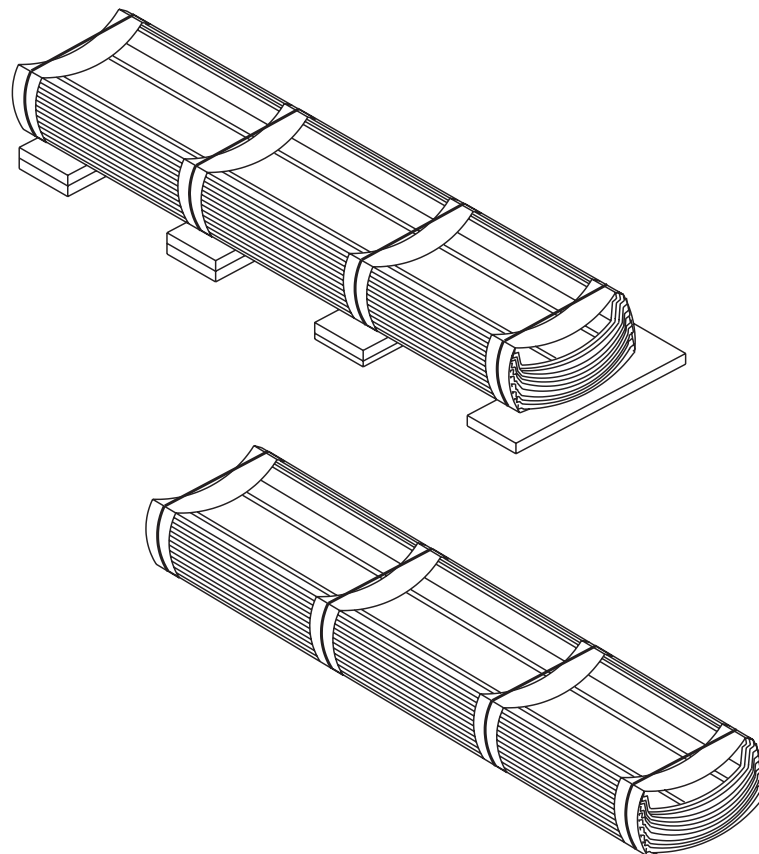
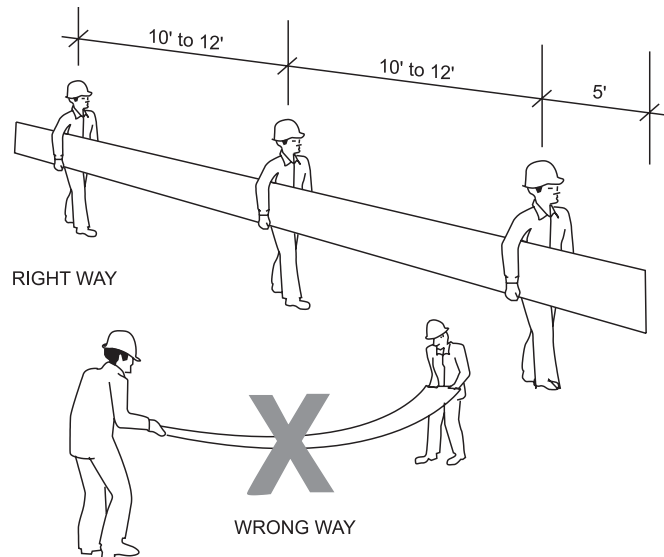

Protective gloves should always be used while handling panels. OSHA safety regulations must be followed at all times.

STEP 1 ERECTION SEQUENCE

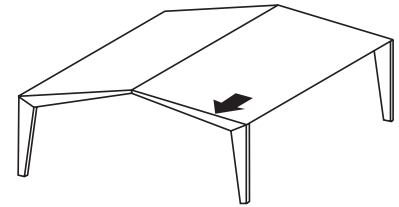

RAKE SUPPORT

Attach the rake support on top of the rake angle with the proper self-drilling fasteners on 2'-0" centers with a fastener in the first and last prepunched slot. The vertical leg is to be installed square with the eave. Center fasteners in slots.

FLOATING SYSTEM

FASTENER #5

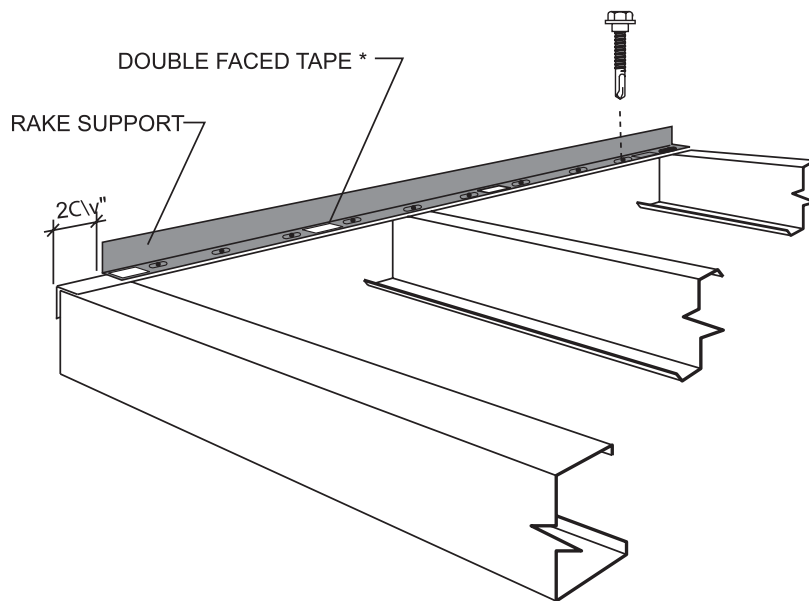

FASTENER REQUIREMENTS

- Floating System
Purlins- Fastener #5

IT IS IMPORTANT THAT THE RAKE SUPPORT IS INSTALLED STRAIGHT AND SQUARE WITH THE EAVE AS IT CONTROLS THE ALIGNMENT OF THE ROOF SYSTEM.

Install 6" pieces of double faced tape(not by building manufacturer) on 3'-0" centers to the top of the horizontal leg of the rake support. This will help hold the insulation in place at the rake.

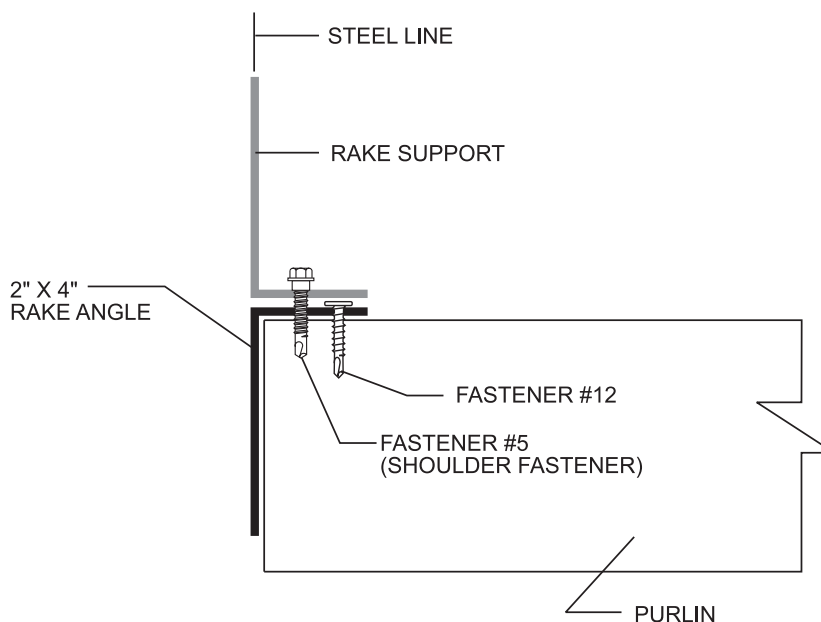

*Not by Building Manufacturer

CAUTION

It is important that shoulder fasteners are installed through the CENTER of the slotted holes of the rake support to allow for expansion and contraction.

CAUTION

ALL PRIMARY AND SECONDARY FRAMING SHOULD BE ERECTED, PLUMBED, AND BOLTS TIGHTENED PRIOR TO SHEETING.

STEP 2 ERECTION SEQUENCE

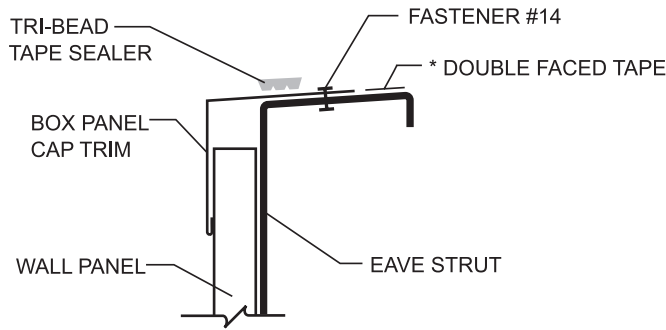

WALL PANEL INSTALLED BEFORE ROOF

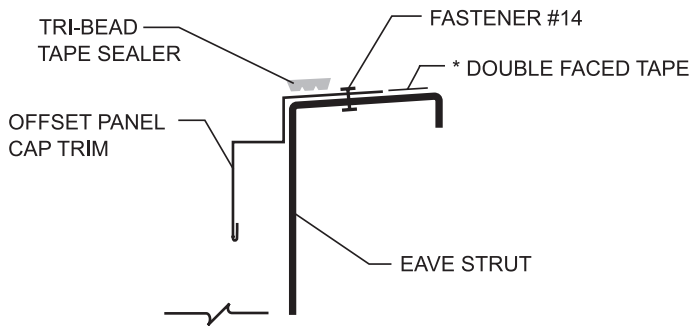

WALL PANEL INSTALLED BEFORE OR AFTER ROOF

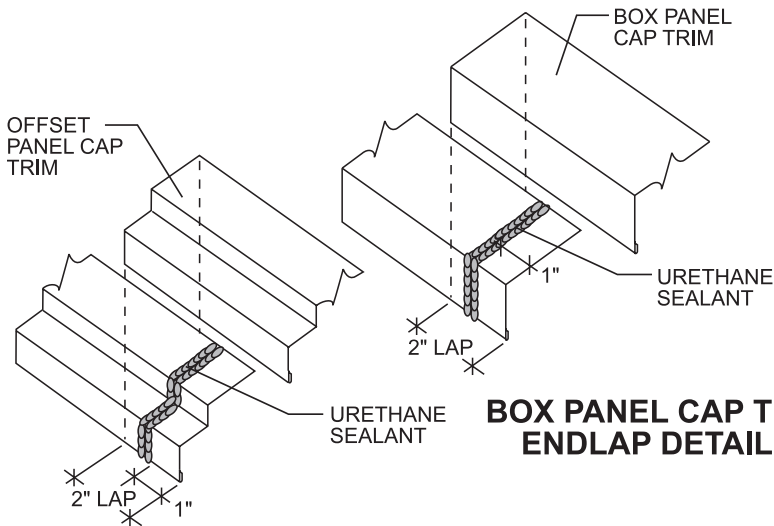

**BOX PANEL CAP TRIM
ENDLAP DETAIL**

**OFFSET PANEL CAP
TRIM ENDLAP DETAIL**

*Not by Building Manufacturer

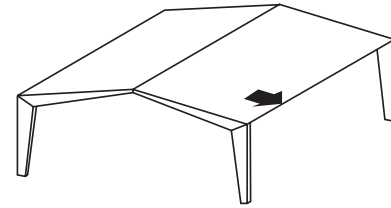

LOW SYSTEM EAVE

For applications in which the wall panels have already been erected, install box panel cap trim or offset panel cap trim to the eave strut with Fastener #14. Trim must be pulled tight to wall panels before fastening to eave strut. For applications in which the wall panels have not been erected, use offset panel cap trim.

Lay Tri-Bead tape sealer on top of the panel cap trim (box or offset).

Install double faced tape along the length of the top leg of the panel cap trim (box or offset). Double faced tape must be upslope from Tri-Bead tape sealer.

Lap box or offset panel cap trim 2". Apply two beads of urethane sealant between the trim pieces, approximately 1" from the end of the bottom piece.

STEP 2A ERECTION SEQUENCE

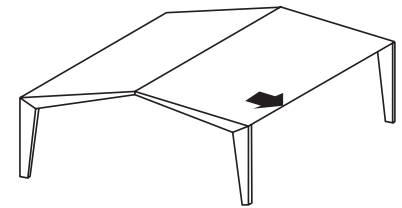

LOW SYSTEM EAVE/ METAL INSIDE CLOSURE

Using Fastener #1, attach the first inside closure to the eave strut, locating the face of the inside closure with the steel line. **NOTE THAT THE FIRST INSIDE CLOSURE MUST BE FIELD CUT IN HALF TO FILL THE VOID UNDER THE PARTIAL RIB.**

Locate additional closures on 24" centers from the first closure to maintain panel module, attaching each with Fastener #1. Install two fasteners per closure. The first fastener should be installed through the slotted hole to allow for any adjustment that may be required. Place Tri-Bead tape sealer on the top and side of each closure to complete the seal at the eave. These may be pre-taped before installation. **To maintain panel module, metal inside closures must be installed at 24" centers. Measure from tab to tab located on the metal inside closure.**

Roll out insulation from eave to peak, laying the side of the insulation on top of the rake support. The first roll should be 3' wide. This will keep insulation sidelaps 1' from panel sidelaps. Allow approximately 4" of insulation to hang past the double faced tape (downslope) before sticking the insulation to the double faced tape. Cut and remove the fiberglass approximately 4" and fold the vapor barrier back over the insulation (upslope).

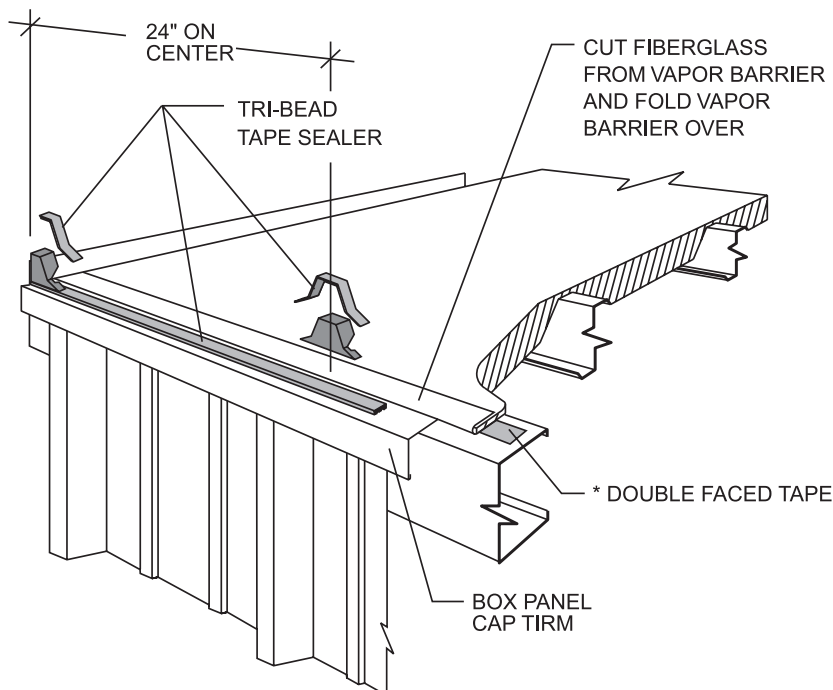
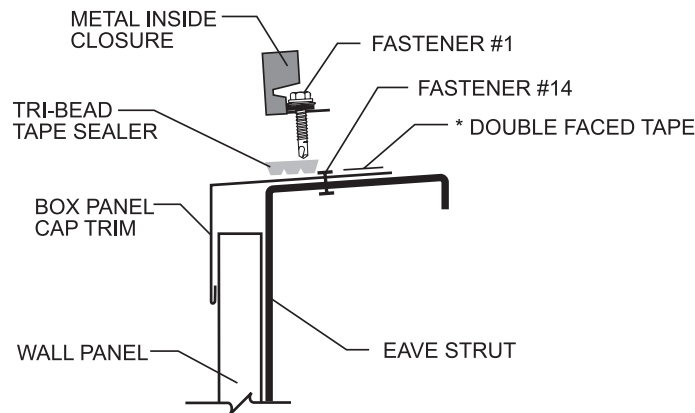

*Not by Building Manufacturer

CAUTION:
The fiberglass insulation must not interfere with the Tri-Bead tape sealer which provides a positive seal at the eave.

STEP 2B ERECTION SEQUENCE

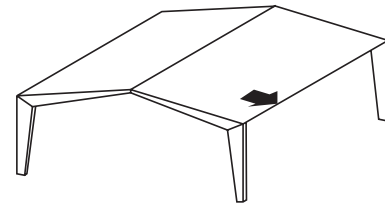
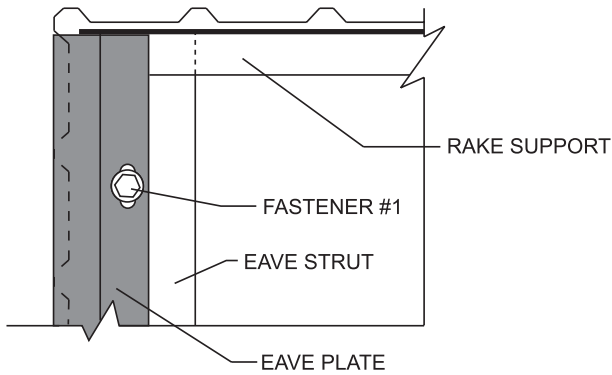

HIGH SYSTEM EAVE

Wall Panels Installed Before Roof

Install high eave plates flush with the outside of the high crowns of the wall panels. Install Fastener #1 in prepunched slot (1'-0" on center) of the eave plate. **The first eave plate will butt against the rake support.** You may install all of the eave plates at this time. Be sure to butt each eave plate end to end without leaving a gap between the plates. Place an 8" length of triple bead tape sealer at each butt joint.

Install box panel cap trim or offset panel cap trim to the top of the eave plates with Fastener #14. Use two fasteners per 10' piece and three fasteners per 20' piece. Trim must be pulled tight to wall panels before fastening to eave plates.

Lay Tri-Bead tape sealer across the top of the box panel cap trim, flush with the outside edge.

Install double faced tape along the length of the top leg of the box panel cap trim. Double faced tape must be upslope from the Tri-Bead tape sealer.

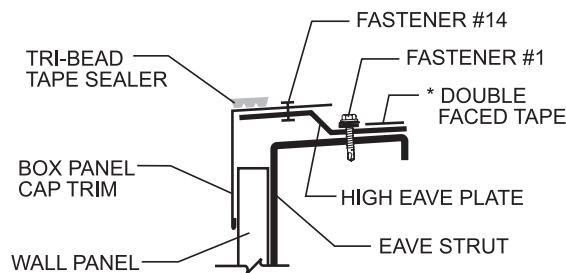

WALL PANEL INSTALLED BEFORE ROOF

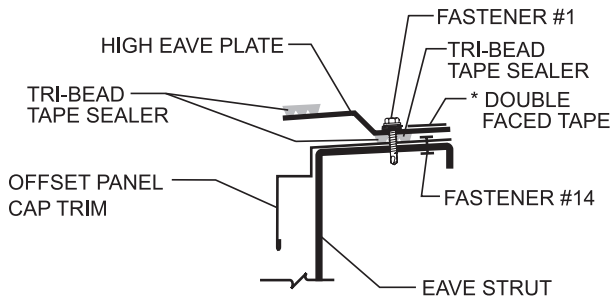

WALL PANEL INSTALLED BEFORE OR AFTER ROOF

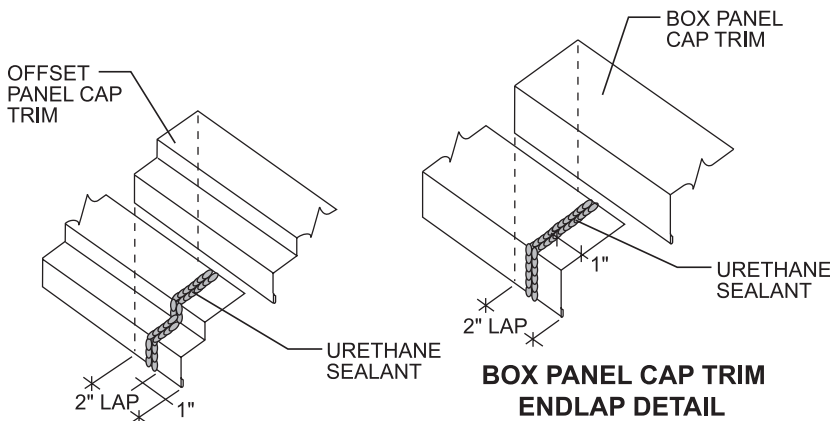

OFFSET PANEL CAP TRIM ENDLAP DETAIL

BOX PANEL CAP TRIM ENDLAP DETAIL

Wall Panels Installed After Roof

Install offset panel cap trim to eave strut with Fastener #14. Use two fasteners per 10' piece and three fasteners per 20' piece.

Install high eave plates flush with the outside of the offset panel cap trim. Install Fastener #1 in each prepunched slot (1'-0" on center) of the eave plate. **The first eave plate will butt against the rake support.** You may install all of the eave plates at this time. Be sure to butt each eave plate end to end without leaving a gap between the plates. Place an 8" length of triple bead tape sealer at each butt joint.

Lay Tri-Bead tape sealer across the top of the eave plates, flush with the outside edge. Install double faced tape along the length of the bottom leg of the eave plate.

TRIM LAPS

Lap box or offset panel cap trim 2". Apply two beads of urethane sealant between the trim pieces, approximately 1" from the end of the bottom piece.

*Not by Building Manufacturer

STEP 2C ERECTION SEQUENCE

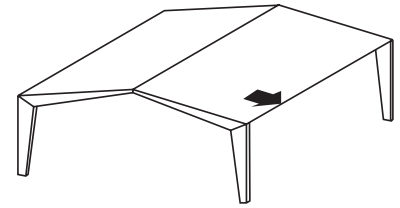

HIGH SYSTEM EAVE/ METAL INSIDE CLOSURE

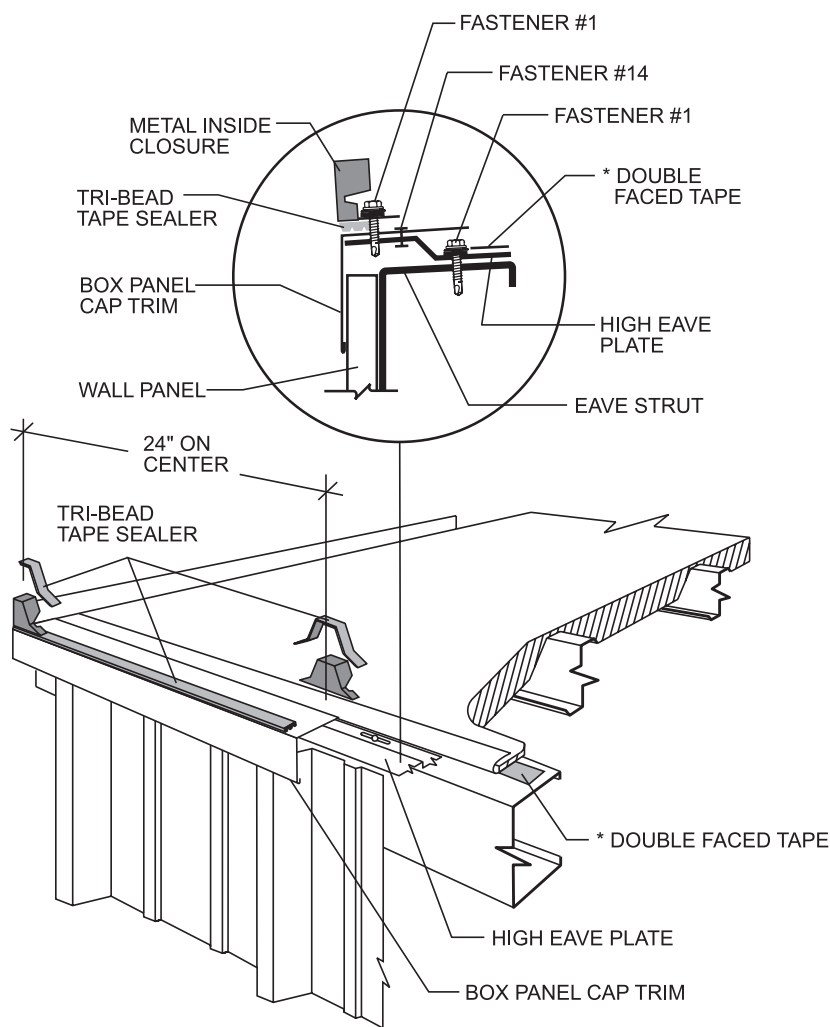

Using Fastener #1, attach the first inside closure to the eave plate, locating the face of the inside closure with the downslope edge of the eave plate. **NOTE THAT THE FIRST INSIDE CLOSURE MUST BE FIELD CUT IN HALF TO FILL THE VOID UNDER THE PARTIAL RIB.**

Locate additional closures on 24" centers from the first closure to maintain panel module, attaching each with Fastener #1. Install two fasteners per closure. The first fastener should be installed through the slotted hole to allow for any adjustment that may be required. Place Tri-Bead tape sealer on the top and side of each closure to complete the seal at the eave. These may be pre-taped before installation. **To maintain panel module, metal inside closures must be installed on 24" centers. Measure from tab to tab located on the metal inside closure.**

Roll out insulation from eave to peak, laying the side of the insulation on top of the rake support. The first roll should be 3' wide. This will keep insulation sidelaps 1' from panel sidelaps. Allow approximately 4" of insulation to hang past the double faced tape (downslope) before sticking the insulation to the double faced tape. Cut and remove the fiberglass approximately 4" and fold the vapor barrier back over the insulation (upslope).

CAUTION:

The fiberglass insulation must not interfere with the Tri-Bead tape sealer which provides a positive seal at the eave.

*Not by Building Manufacturer

STEP 3 ERECTION SEQUENCE

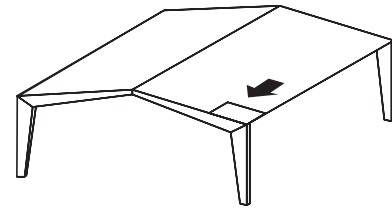
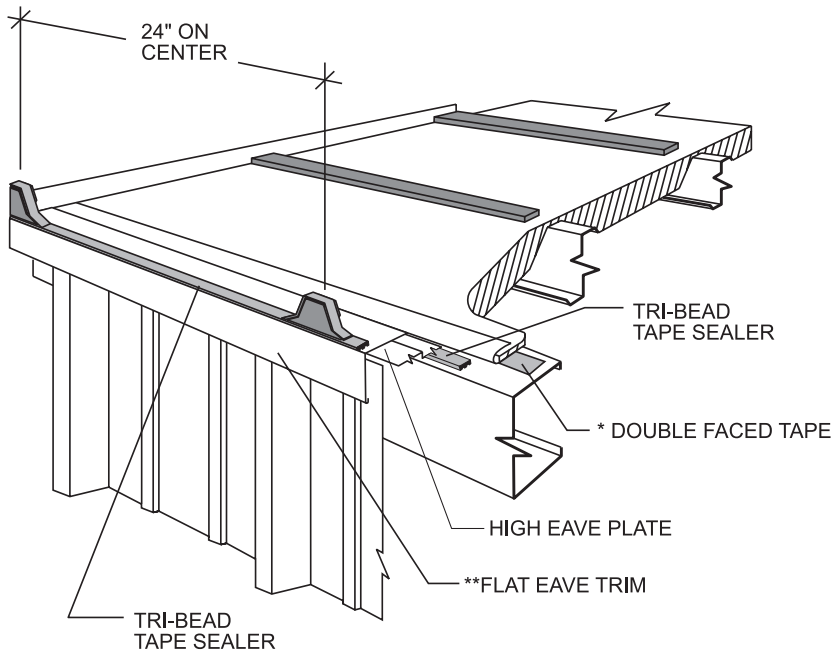

THERMAL SPACER (FOR HIGH SYSTEM ONLY)

Position the thermal spacer on top of the insulation over each purlin and against the rake support prior to installing the roof panel.

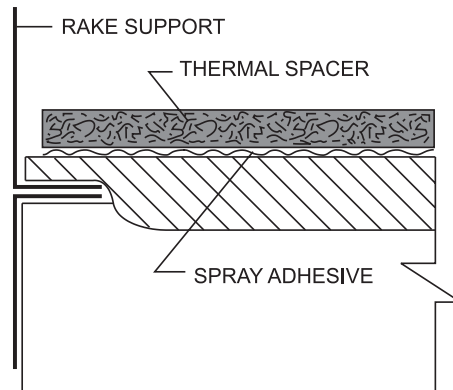
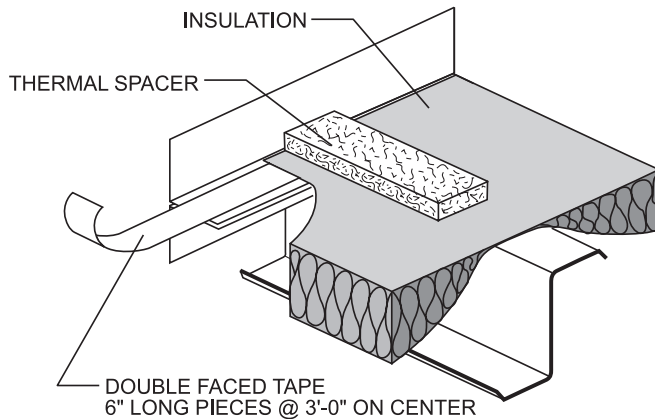

Using spray adhesive, (not by building manufacturer) adhere the thermal spacer to the insulation. The thermal spacer increases the insulation capacity along the purlins.

*Not by Building Manufacturer

STEP 4 ERECTION SEQUENCE

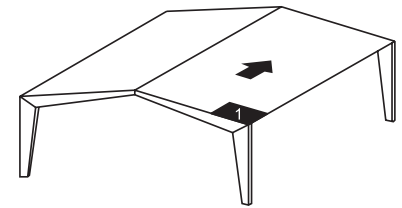

FIRST PANEL

Apply minor rib tape sealer to the underside of the minor ribs of the panel. Position so that this tape sealer will cross the Tri-Bead tape sealer on the eave trim (for low systems) or on the high eave plate (for high systems) when the panel is installed.

Position the panel so that it overhangs the eave strut by the thickness of the wall covering plus 3 1/2". The upper end of the panel must be 7" beyond the web of the purlin.

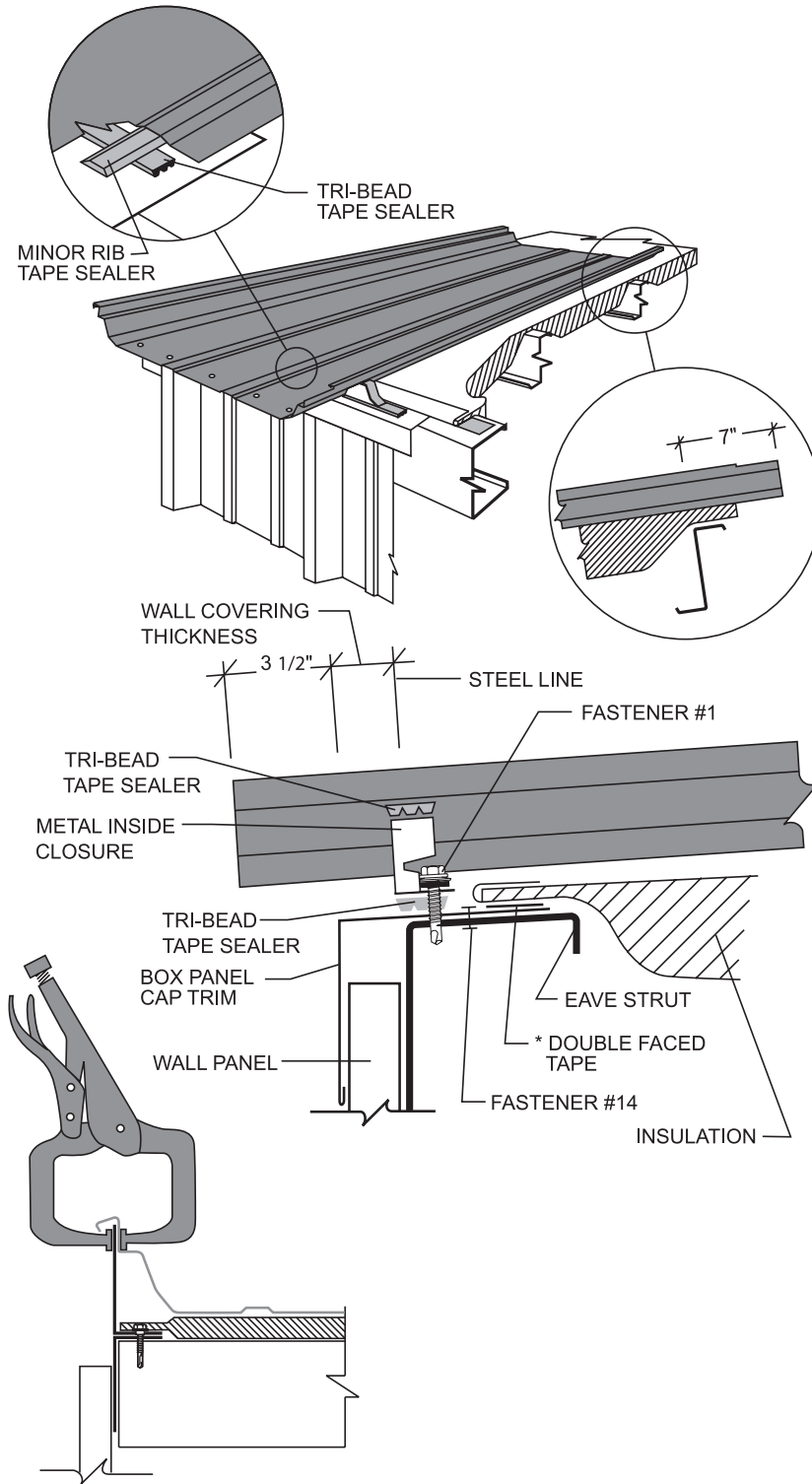

PREPUNCHED PANEL HOLES AT THE EAVE ARE INTENDED TO BE PART OF THE GUTTER OVERHANG AND WILL BE HIDDEN BY THE GUTTER. FOR A BUILDING WITH SCULPTURED EAVE TRIM, THE PREPUNCHED HOLES WILL BE USED TO ATTACH THE EAVE TRIM TO THE PANEL.

Lay the female lip of the panel over the rake support. To prevent wind damage, secure the female lip to the rake support with a "C" clamp or temporary fasteners. Fasteners must go through rake support (Fastener #1E). The panel will not be fastened permanently to the rake support until the rake trim is installed.

*Not by Building Manufacturer

STEP 4 - Continued

ERECTION SEQUENCE

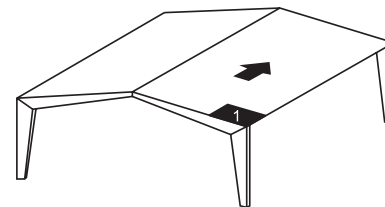
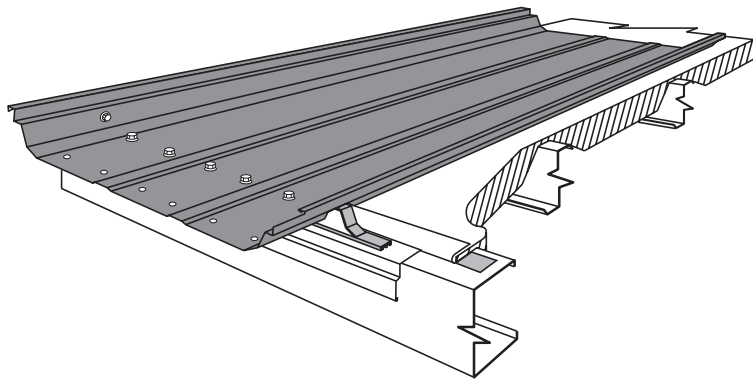

FIRST PANEL (Continued)

Attach the panel to the eave strut and metal inside closures with Fastener #1E. Eight fasteners are required at this location.

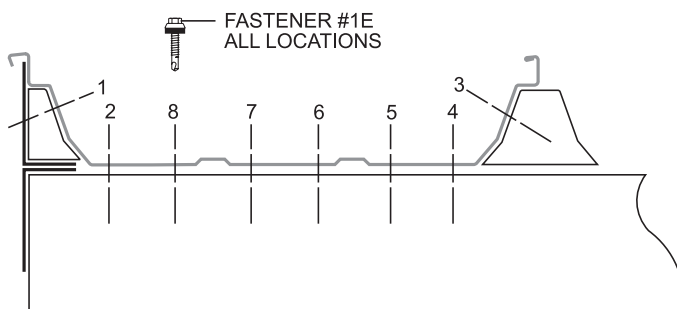

NOTE: IT IS ESSENTIAL THAT THE ERECTOR MAINTAIN A 24" MODULE AT THE EAVE, WITH THE PROPER INSTALLATION OF THE INSIDE CLOSURES AND BY INSTALLING FASTENERS IN THE PROPER SEQUENCE.

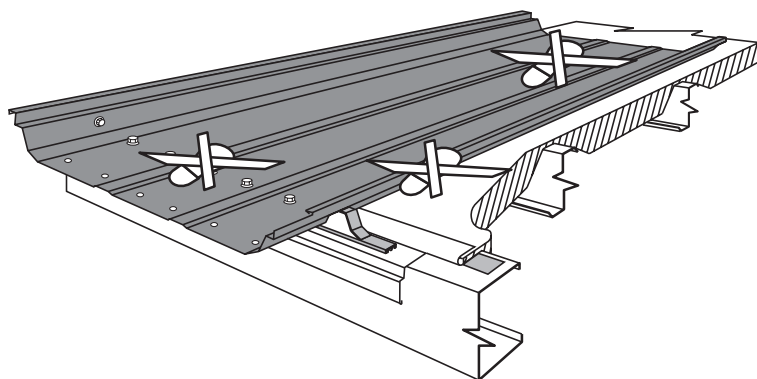

CAUTION

Do not, under any circumstance, step on the panel at the seam or at the panel ends until the adjacent side, end panels or eave fasteners are fully attached. The roof panel may not support the weight of a man at these locations and could affect panel module.

CAUTION

The roof should be swept clean of any drill shavings at the end of each day to prevent rust.

STEP 5 ERECTION SEQUENCE

FIELD MODIFY (FIRST RUN ONLY)

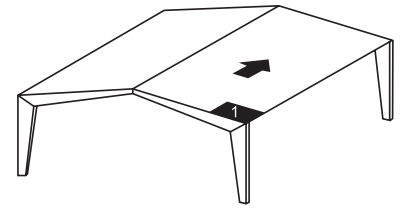
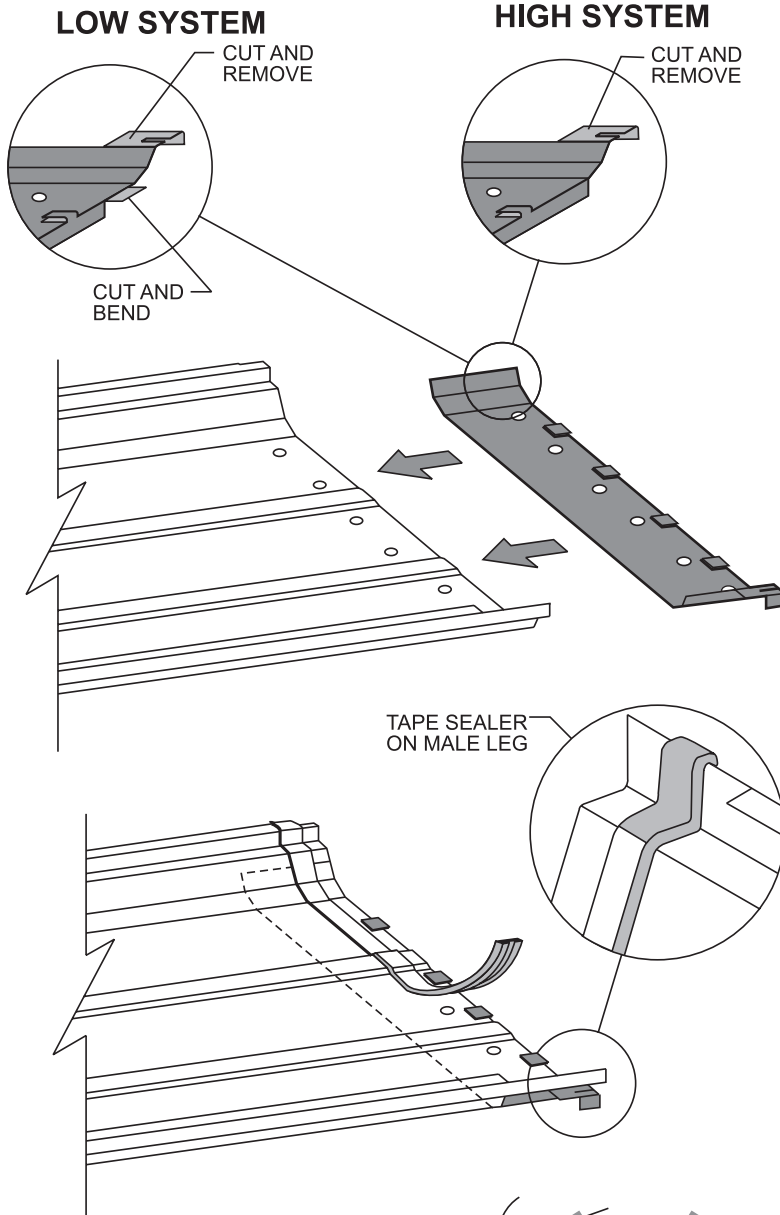

BACK-UP PLATE*

NOTE

All back-up plates on first panel run will require field modification to avoid fouling rake support.

Slide a back-up plate onto end of panel; make sure the teeth on top of the back-up plate are on top of the panel. Visually check to see that the holes in the panel align with the holes in the back-up plate.

Place Tri-Bead tape sealer over the entire width of the panel. It must be centered directly over the pre-punched holes, following the panel configuration.

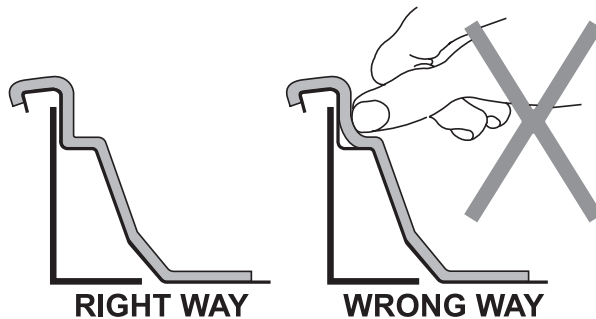

CAUTION

Forcing the tape sealer back into the corners will lessen the thickness of the tape sealer where it is needed most.

*Protected by U.S. Patent No. 4,655,020

STEP 6 ERECTION SEQUENCE

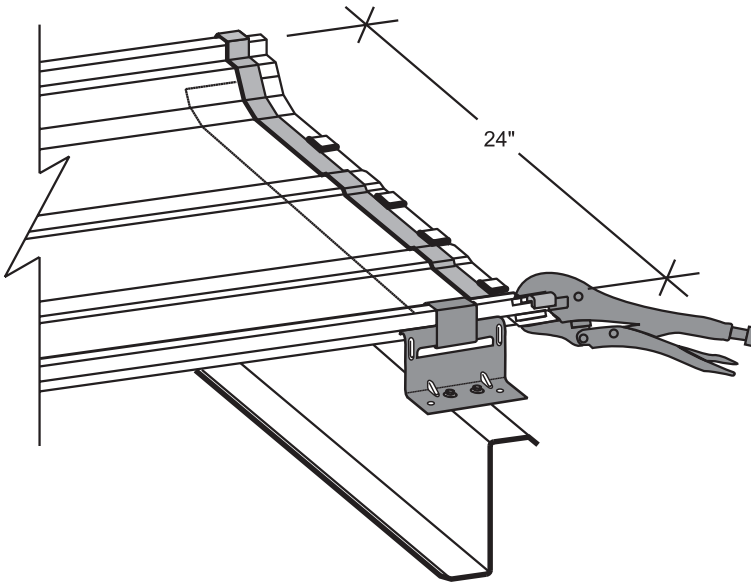
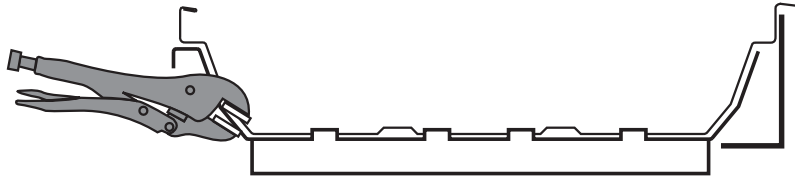

• Position the clip over the male leg of the panel as shown, and rotate clip downward.



• With the upper clip firmly seated, position the base firmly against the purlin flange.

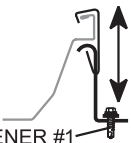

FASTENER #1

• When properly positioned, the vertical legs of the upper and lower sections of the clip will be pointed upward, as shown.

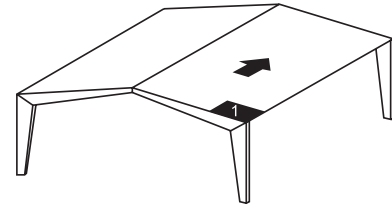

CLIP INSTALLATION

Before installing the first clip, clamp the male side of the panel to the side of the back-up plate with a pair of Vise-Grip® locking pliers. This will help maintain panel module at the endlaps.

Install a clip on the male leg of the panel at the endlap. This should be the first clip installed as it controls the 24" module for the remainder of the panel. Install clips on all remaining purlins.

FASTENER REQUIREMENTS

Purlins - Fastener #1
Joists - Fastener #6
(Two fasteners per clip)

CAUTION

For UL 90 Roofs, see the Central Seam Plus product guide for special requirements.

CAUTION

The panel clip has factory applied mastic in the upper lip. This mastic is compressed when the clip is rotated in place. If, for some reason, a clip must be removed, a new clip must be used.

IMPORTANT

As each clip is installed, maintain a 24" panel module.

NOTE

The floating clip is designed so it can only be properly seated when the upper portion of the clip (the tab) is centered on the base.

STEP 7 ERECTION SEQUENCE

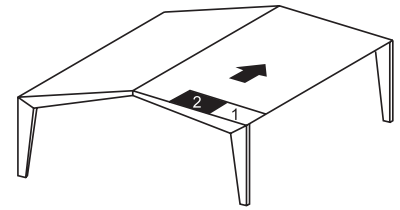
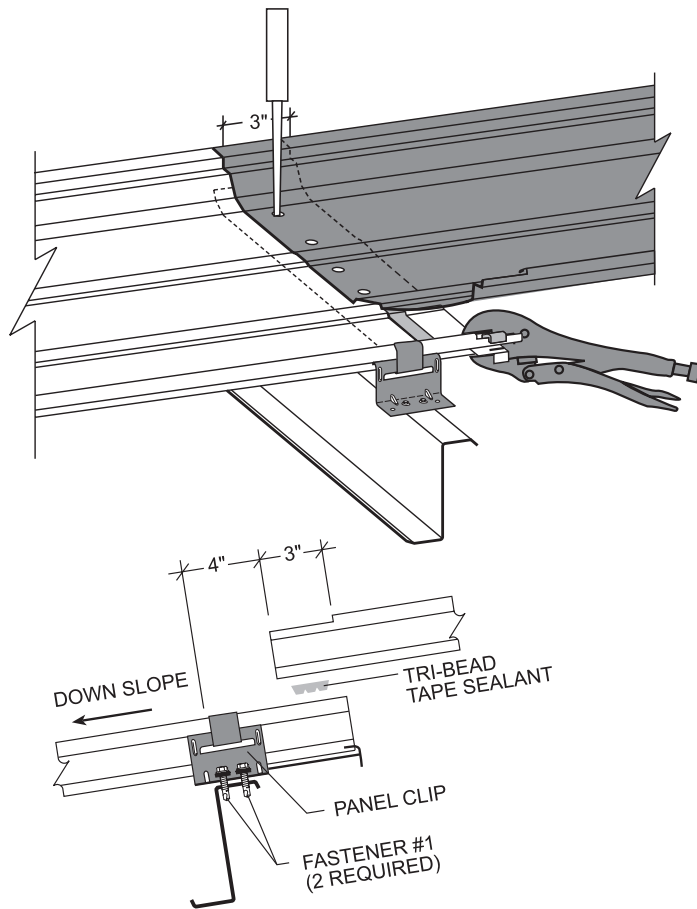

ENDLAP-PANEL

NOTE

Step 7 applies only where more than one panel is used in a single slope.

Position female lip of upper panel over rake support, while holding male side of panel up away from the tape sealer. Using an awl, align the hole nearest the female side of the top panel with the corresponding hole in the lower panel and the back-up plate.

Once this is accomplished, rotate the male side of the upper panel down to rest on the Vise-Grip® locking pliers.

Make sure the panel notches are aligned.

Remove awl and insert in the middle hole nearest the male leg. Install Fastener #1E in the hole by the female leg.

CAUTION

The roof should be swept clean of any drill shavings at the end of each day to prevent rust.

STEP 8 ERECTION SEQUENCE

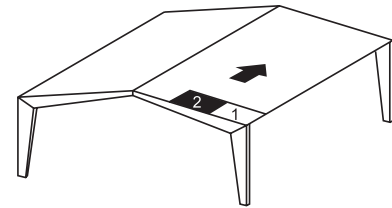
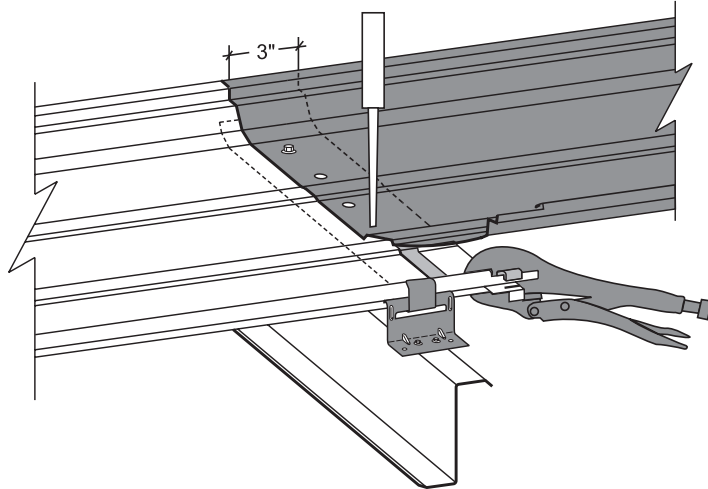

STANDARD ENDLAP

NOTE

Step 8 applies only where more than one panel is used in a single slope.

All holes in the upper and lower panels and the back-up plate should now be aligned. Make sure that the panel notches are aligned.

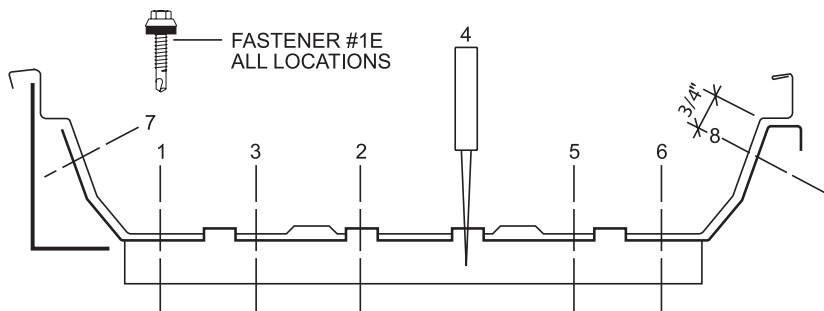

FASTENER SEQUENCE FIRST RUN - ENDLAP

Install Fastener #1E in sequence 2 and 3. Remove Vise-Grip® locking pliers and install remaining fasteners in sequence 4, 5, 6, 7, 8.

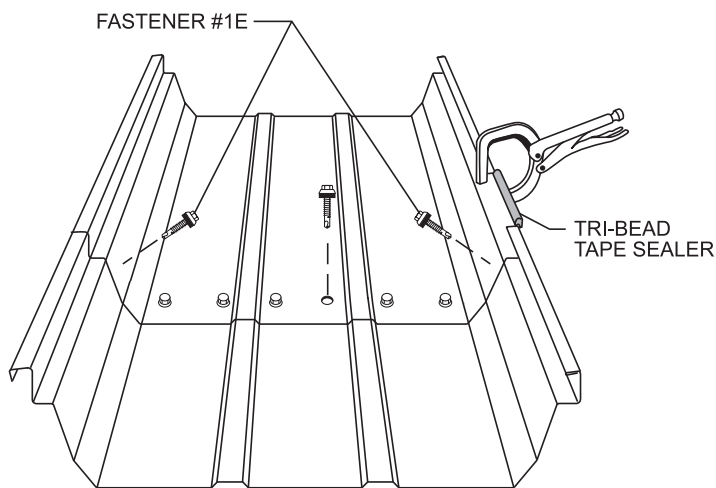

APPLY TRI-BEAD TAPE SEALER OVER THE NOTCHED PORTION OF THE MALE LEGS.

Repeat the endlap procedures as required for each panel until the ridge or high eave is reached.

STEP 9 ERECTION SEQUENCE

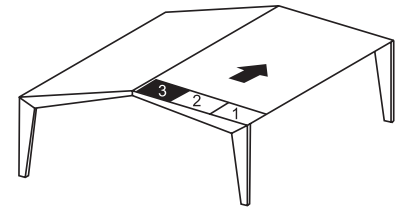

RIDGE PANEL

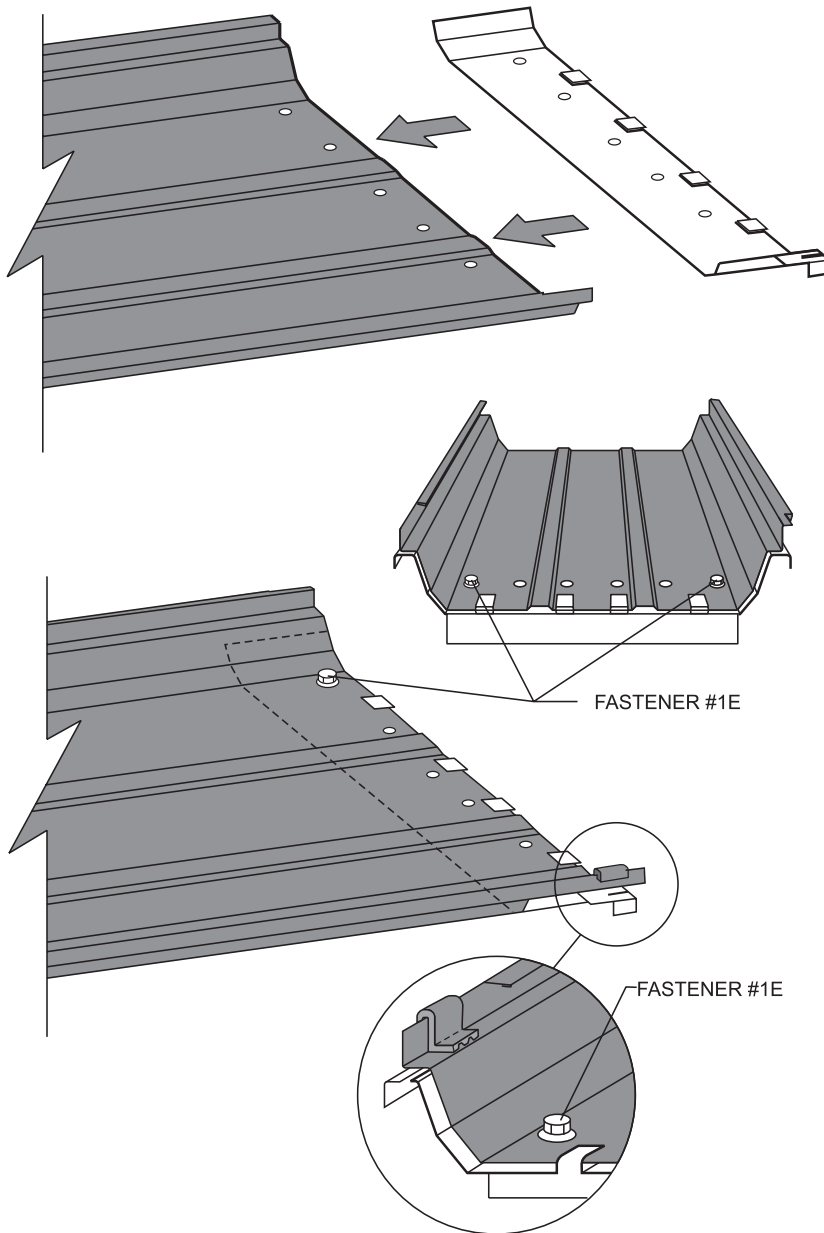

At the ridge, install a back-up plate as in Step 5. The back-up plate is necessary to maintain panel module.

Temporarily fasten the panel to the back-up plate with Fastener #1E in the prepunched hole adjacent to each panel rib.

Install Tri-Bead tape sealer across the profile of the male leg at the ridge. This tape sealer will be centered 11/2" from end of panel, which is also in alignment with the prepunched holes. **DO NOT INSTALL TAPE SEALER ACROSS PANEL AT RIDGE AT THIS TIME.**

Install clips on ridge panel as in Step 6.

CAUTION
Placing the tape sealer over the male leg of the panel is important. Without it, water could be driven behind the outside closure by a strong wind.

STEP 10 ERECTION SEQUENCE

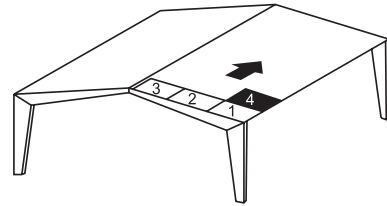

SUBSEQUENT RUNS EAVE

Apply tape sealer to the male leg of the first panel run directly over the inside closure. This will prevent water infiltration through the end of the seam. Install the next run of insulation and another inside closure using Fastener #1. The second run of roof is now ready to install.

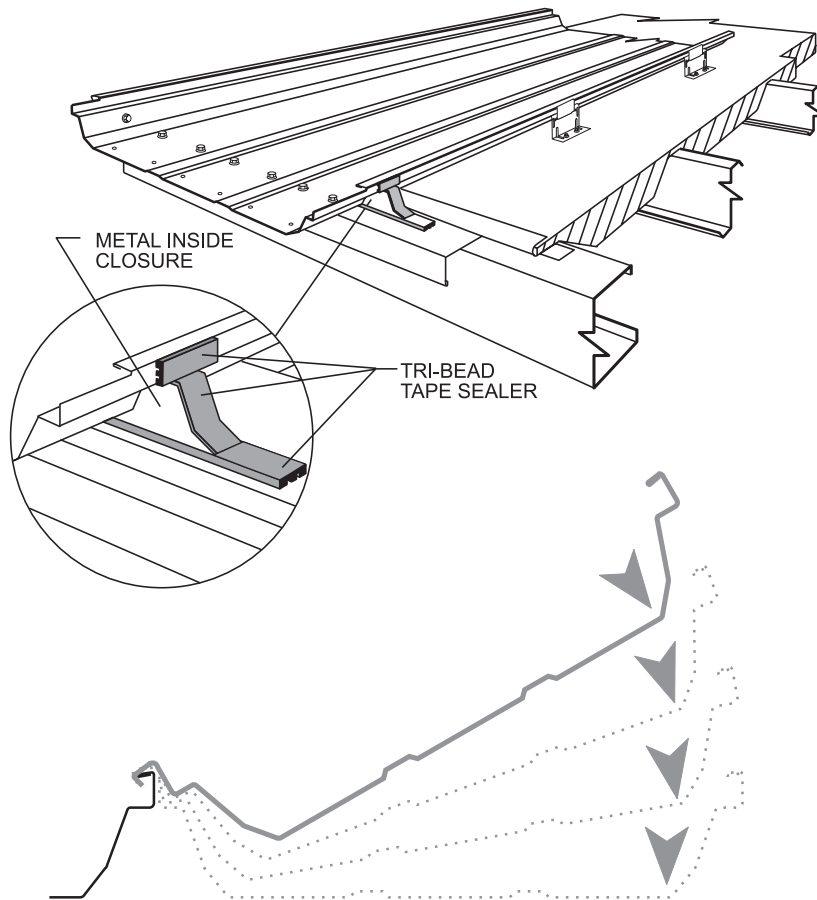

Holding the male side of the next panel up, lay the female lip on top of the male leg of the adjacent panel and align it flush at the eave. Rotate the panel down, visually checking that the female lip is engaged onto the male leg of the adjacent panel along its entire length. **IF THE PANEL MUST BE RAISED FOR FURTHER ALIGNMENT, CARE SHOULD BE TAKEN TO AVOID PULLING THE FACTORY APPLIED MASTIC FROM THE FEMALE LIP.**

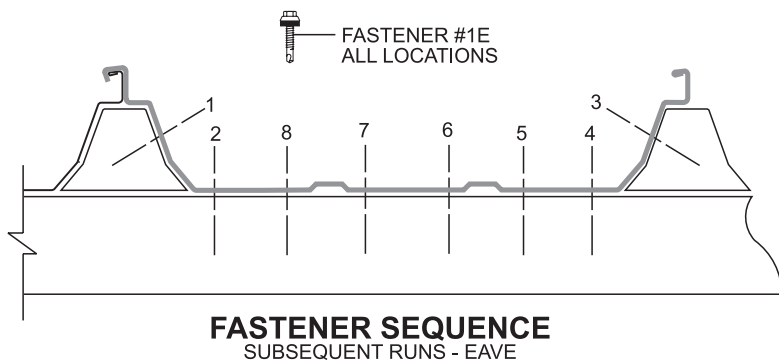

Install Fastener #1E at eave in the recommended sequence. Eight fasteners are required at this location.

CAUTION
The roof should be swept clean of any drill shavings at the end of each day to prevent rust.

STEP 11 ERECTION SEQUENCE

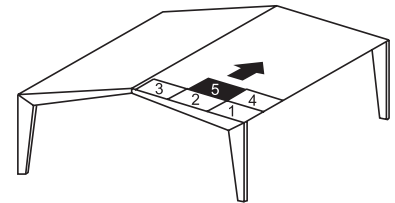
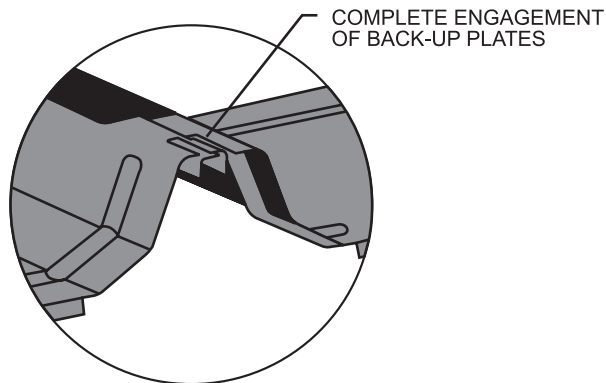

SUBSEQUENT RUNS ENDLAP

Install back-up plate and tape sealer as in Step 5. However, on this and all subsequent runs, care must be taken to engage the tab on the side of the back-up plate into the slot of the adjacent back-up plate. This procedure will assist in maintaining a 24" panel module.

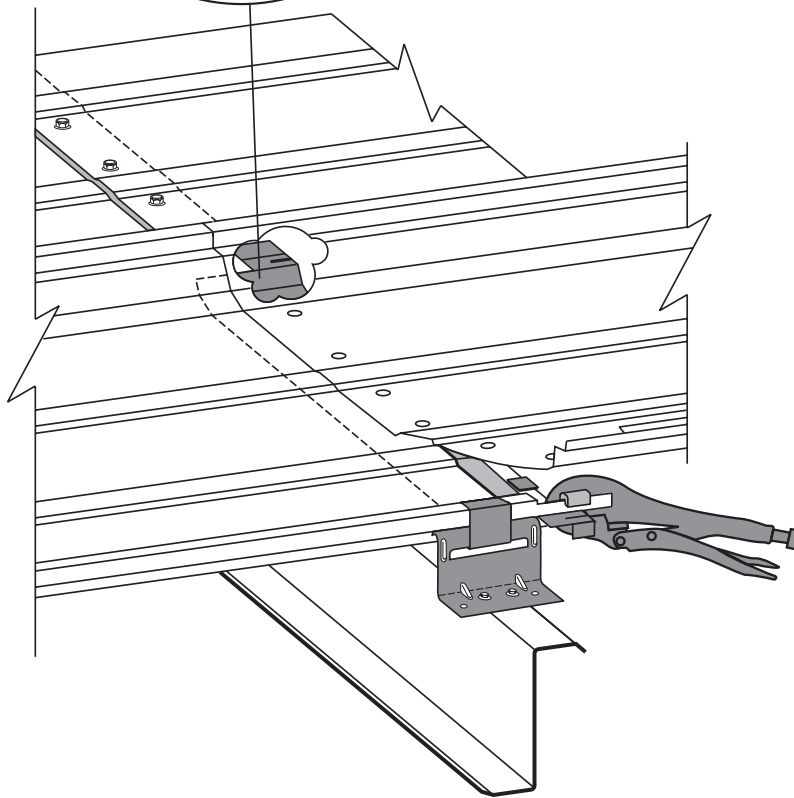

Install clips as described in Step 6.

Install upper panel as described in Steps 7 & 8.

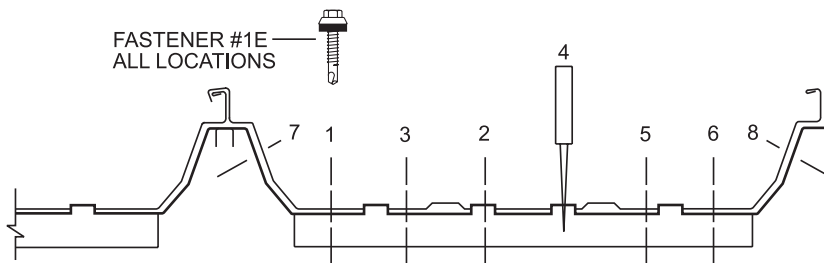

Repeat the endlap procedures as required for each panel until the ridge is reached.

FASTENER SEQUENCE
SUBSEQUENT RUNS - ENDLAP

STEP 12 ERECTION SEQUENCE

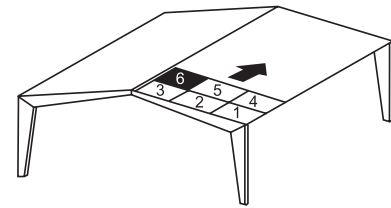
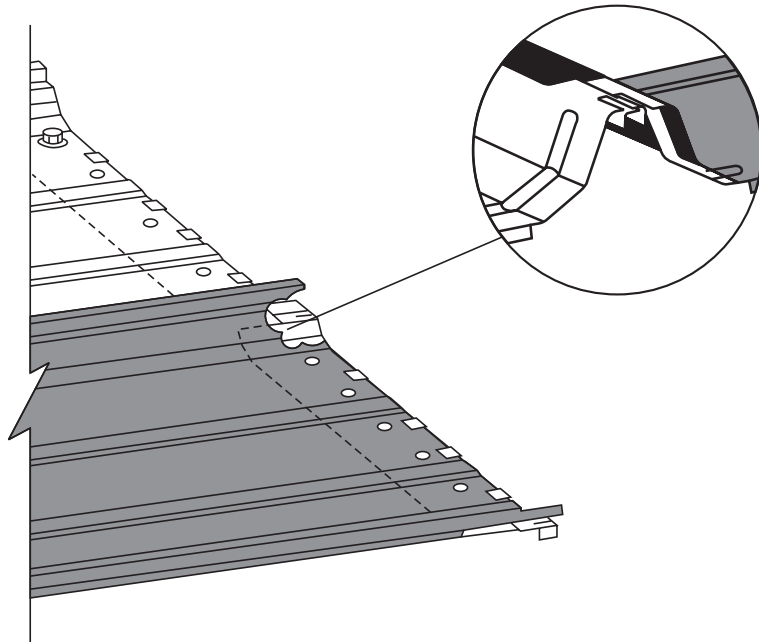

SUBSEQUENT RUNS RIDGE

Install back-up plate, taking care to engage the tab on the side with the slot on the adjacent back-up plate.

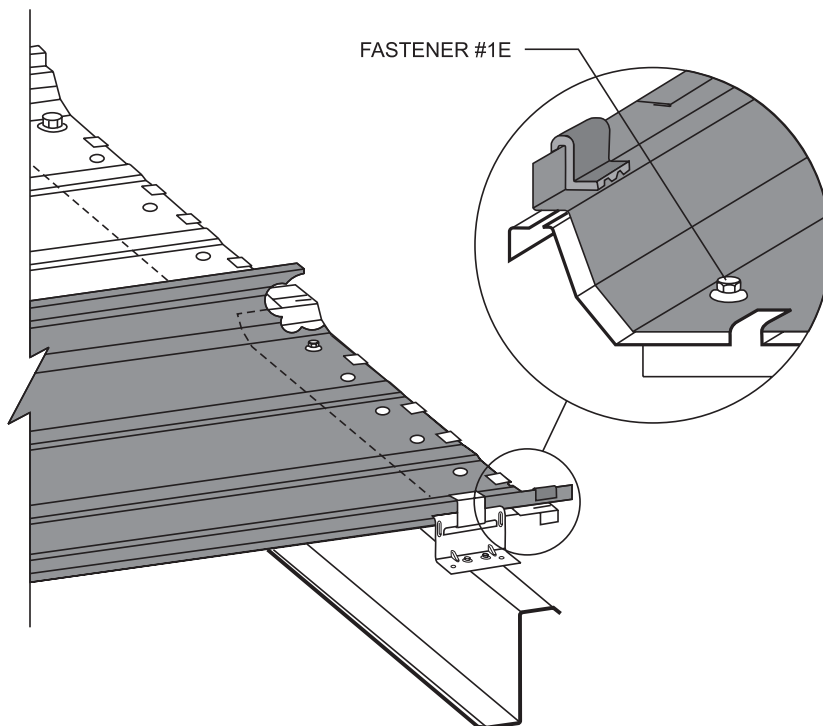

Install temporary Fastener #1E and Tri-Bead tape sealer as described in Step 9.

Install clips as described in Step 6.

CAUTION

Installing tape sealer to the male leg is important without it, water could be driven behind the outside closure by a strong wind.

STEP 13 ERECTION SEQUENCE



The specific seamer you rent may be different than the one shown in this guide. Follow all directions provided by the seamer rental company you select. An approved list of seamer vendors can be found on our website.

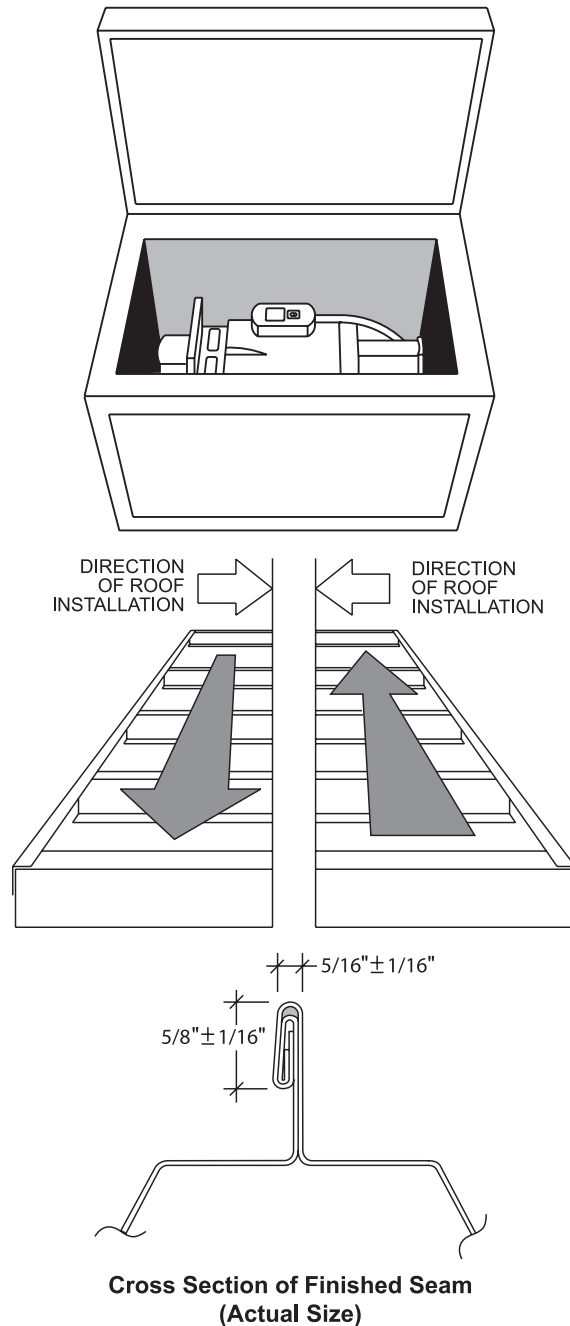

**Cross Section of Finished Seam
(Actual Size)**

SEAMING PANEL SIDELAPS

The seamer comes in a specially designed box accompanied by a field manual and a hand seaming tool.

READ THE SEAMER MANUAL THOROUGHLY BEFORE STARTING THE SEAMING OPERATION. FAILURE TO ADHERE TO THESE INSTRUCTIONS MAY RESULT IN PERSONAL INJURY AND DAMAGE TO THE SEAMER AND/OR PANELS. THE ERECTOR WILL BE HELD LIABLE FOR ANY COSTS INCURRED FOR REPLACEMENT OR REPAIR.

PRE-SEAMING INFORMATION

1. Locate seamer box. Assemble hand seaming tool.
2. Locate power source and check against power requirements in field manual.
3. Check seams for proper engagement.
4. Clean dirt, debris and excess sealant from seams and panel surfaces to avoid interfering with the seaming operation.
5. Panels do not have to be seamed as they are installed. However, to prevent panel separation by a strong wind, panels should be seamed as soon as possible.
ALL PANELS SHOULD BE SEAMED AT THE END OF EACH DAY.

SEAMING OPERATION

To determine the direction of the seaming process, stand at the eave and look upslope. If the roof is being installed from left to right, the seamer will run from ridge to eave. If the roof is being installed from right to left, the seamer will run from eave to ridge.

INSPECTION OF SEAM

A visual inspection of the seam should be made to determine if the seam is forming properly. Check seam against the cross section provided. **IF THE SEAMER IS NOT PRODUCING A FINISHED SEAM IDENTICAL TO THE CROSS SECTION PICTURED, STOP AT ONCE AND CALL THE MANUFACTURER.**

CAUTION

The use of any field seaming machine other than that provided by the manufacturer may damage the panels, void all warranties and will void all engineering data.

STEP 13 - Continued

ERECTION SEQUENCE

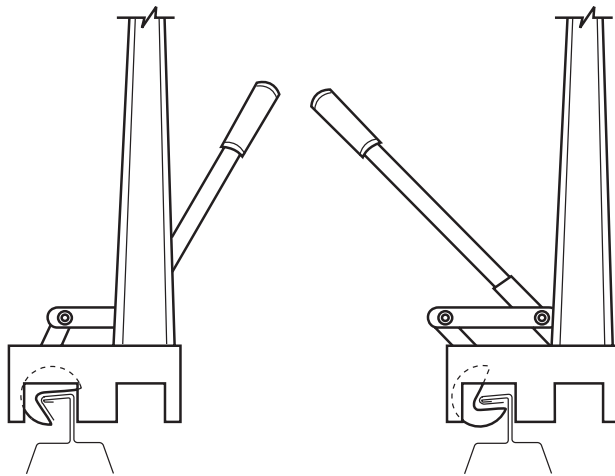

BEGINNING - FIRST PHASE

FINISHED - FIRST PHASE

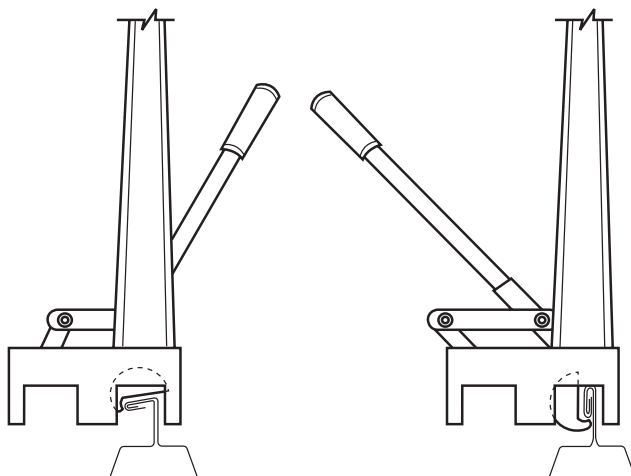
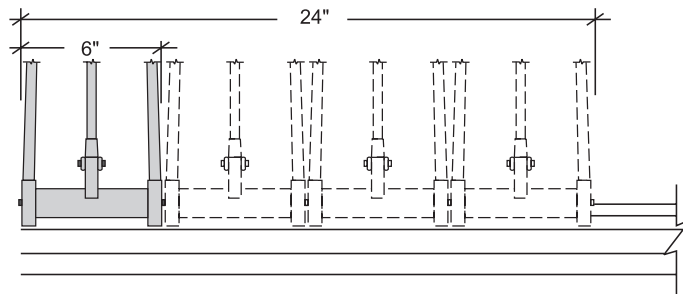

BEGINNING - SECOND PHASE

FINISHED - SECOND PHASE

SEAMING OPERATION

CAUTION

It is critical that the panel seams are crimped and folded as shown before using the electric seamer. Failure to follow these guidelines will result in damaged seams.

To begin seaming, set the hand tool on the seam. Align the edge of the hand tool with the end of the panel. Handles on hand tool should be vertical.

Pull handles apart to crimp female lip. This should be done four times along the seam for a total of 24".

Return to the end of the panel to begin the second stage. Set hand tool onto seam backwards from before. Handles should be leaning away from open side of seam. Pull handles apart to flatten seam. This should be done one time which produces a finished 6" long seam. **The relationship of this 6" of finished seam to the 24" of crimped seam is critical to the proper alignment of the rolls in the electric seamer.**

CAUTION

Do not crimp panel seams. Damage to seams during electric seaming may result.

STEP 13 - Continued ERECTION SEQUENCE

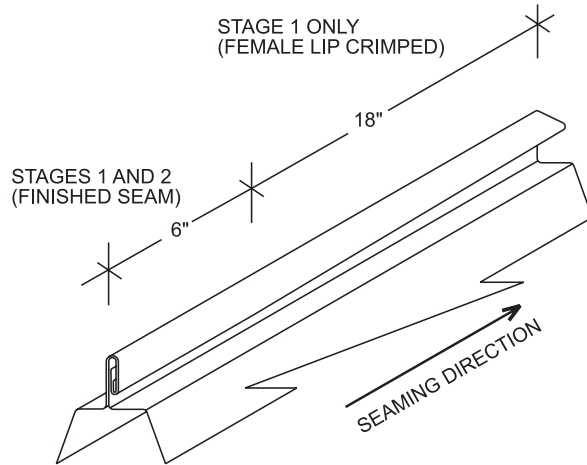

SEAMING OPERATION

The seam is now ready to accept the electric seamer.

Set seamer on seam with the locking arm up and to open side of the seam. The rear wheels should be at the edge of the panel.

Check to see that the last roll of the seamer is on the finished portion of the seam and the other rolls are on the crimped portion of the seam. Push the locking arm down to engage the rolls and turn the seamer on.

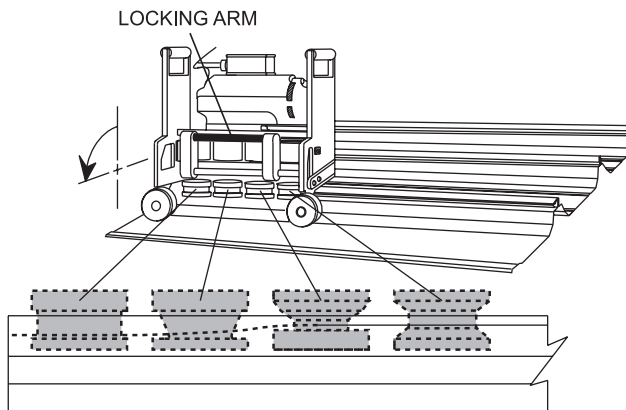

CAUTION

Seamer motor is equipped with 15 amp circuit breaker. Extension cord wire size must be 10 gauge and no longer than 200' from power source.

The manufacturer will not be responsible for motor damage if above instructions are not adhered to.

Stop seamer about one foot from ridge. Disengage locking arm and remove the electric seamer.

Finish seam with hand tool by first crimping the remaining portion of female lip. Then, using the second stage of the hand tool, fold and finish the seam. Repeat this procedure for all panels.

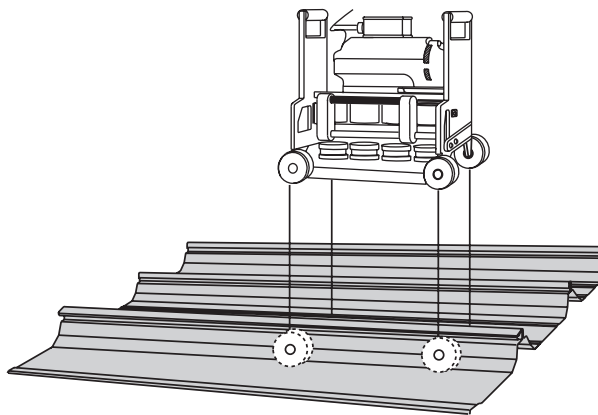

STEP 14 ERECTION SEQUENCE

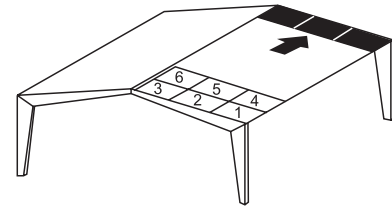
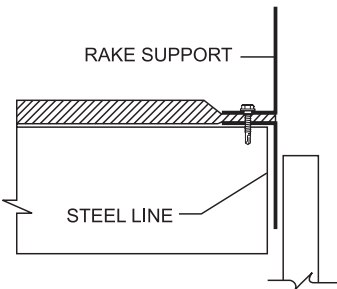
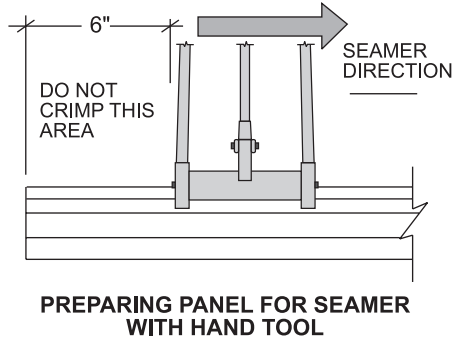

LAST PANEL RUN

This roof system is designed to finish in the high on even footage buildings by using 24" or 18" panels on the last run.

With insulation in place, install rake support along steel line.

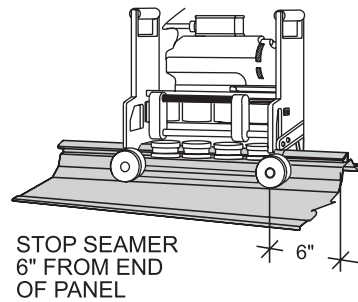
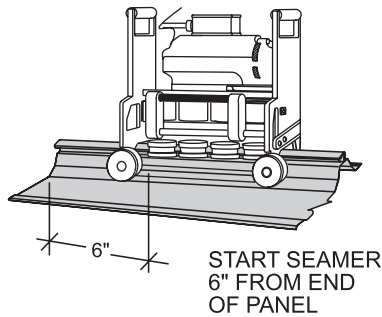

FLATTENING MALE LEG BEFORE PANEL INSTALLATION

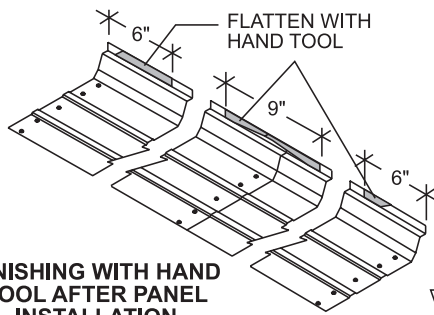

FINISHING WITH HAND TOOL AFTER PANEL INSTALLATION

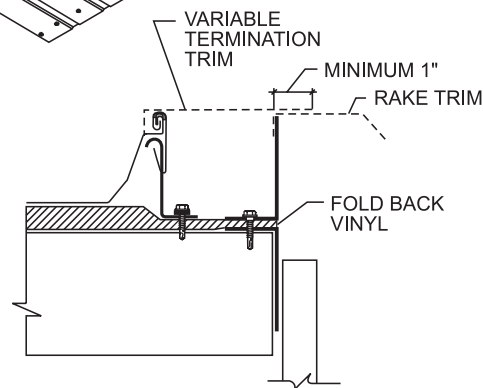

FINISHING ON MODULE

If your roof is finishing on module, the male leg of the last panel run will need to be flattened before installation, with the exception of the first and the last 6" of each panel. This will allow for proper panel engagement at endlaps once panels are installed. Use the hand tool to flatten the male leg 6" from the starting end. (Refer to legend plate on seamer to determine the end that the seamer will start from.) With locking bar up, place seamer on male leg so that the last two rolls of the seamer are on the flattened portion of the seam. The first two rolls will be under the unflattened portion of the seam. Lower locking bar and run seamer to within 6" of the end of the panel. Raise locking bar and remove seamer. Repeat this procedure for all panels. Install panels as usual. Use hand tool to finish the unflattened portion of the male leg at the eave, ridge and endlaps.

FINISHING OFF MODULE

If the panel ends 2" - 6" away from the rake support due to an out-of-square condition or other factors, simply install the panel clips and run seamer over male leg. This will lock the clips in place and flatten the male leg. This system allows for the roof to be trimmed in the high.

CAUTION

The seamer will not support itself while flattening the male leg on the last run. It must be supported during this operation.

STEP 14A ERECTION SEQUENCE

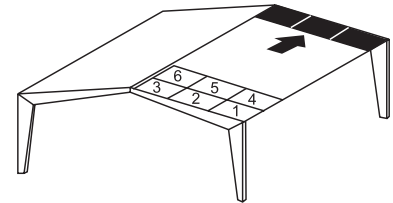
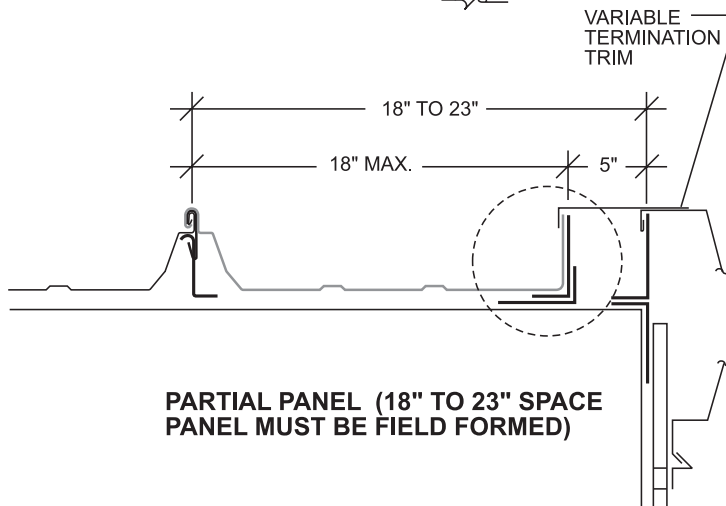
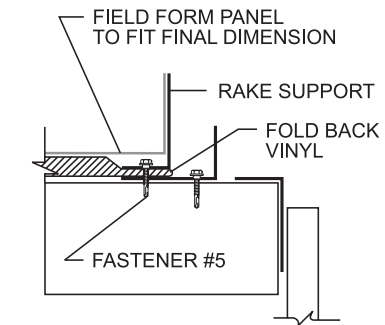
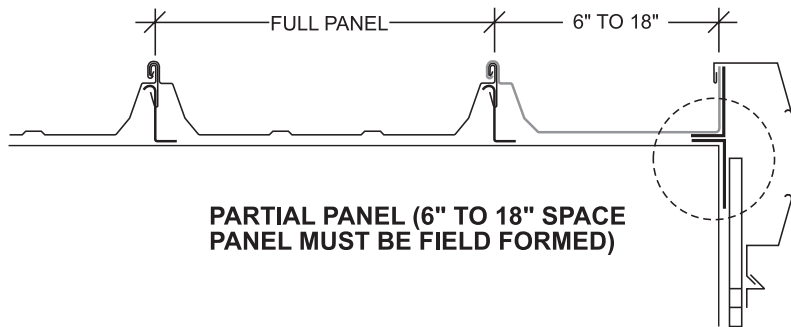
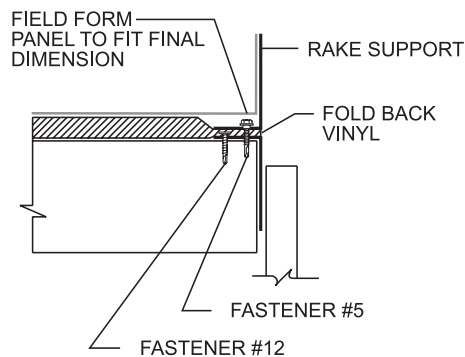

LAST PANEL RUN (OPTIONAL)

The roof is designed to finish in the high on even footage buildings. Odd length buildings and variations in erection practices may dictate that an alternate detail be used.

When terminating in an odd dimension, field cut and bend a 3" vertical leg on the panel.

After laying the last insulation run, install the field formed panel. Temporarily fasten the formed leg of the panel to the rake support with Vice Grips®, or temporary fasteners (#1E).

The combination of field formed panel and Variable Termination Trim may be used to accommodate large dimensions as shown.

CAUTION

The roof should be swept clean of any drill shavings at the end of each day to prevent rust.

STEP 15 ERECTION SEQUENCE

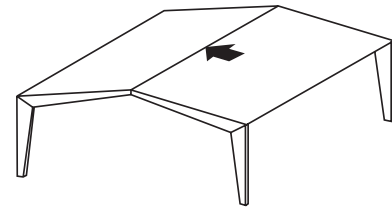
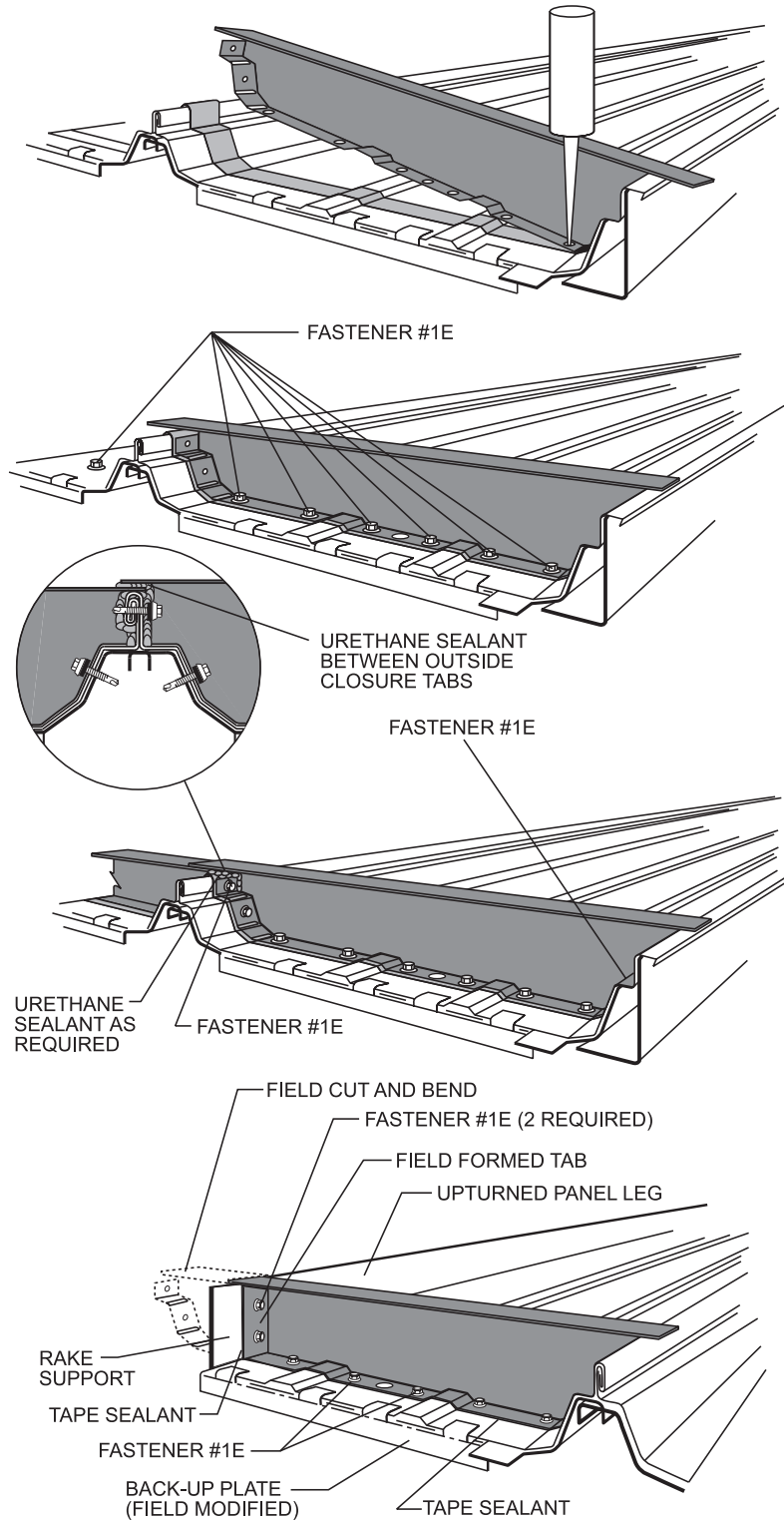

OUTSIDE CLOSURE

After all panel runs are installed and seamed, return to first panel run at the ridge. Remove temporary fasteners from panel and install Tri-Bead tape sealer across full width of panel, covering the prepunched holes.

Rotate outside closure into position contacting the female side of the panel first. Using an awl, align the first hole on the female side of the outside closure with the corresponding hole in the panel and back-up plate. Remove the awl and install Fastener #1E in this hole.

Push the other end of the outside closure into position and align the holes with the awl. Remove the awl and install Fastener #1E in all remaining holes except for the hole at the panel seam. **Do not install the panel seam fastener at this time.**

Install all outside closures on both sides of the ridge.

If the last panel run was field modified, the final outside closure on the last panel will require field modification as well. A tab should be formed on the end of the outside closure for attachment to the upturned leg of the roof panel (field formed). This tab should be attached to the panel with Fastener #1E, two required.

Install Fastener #1E in remaining hole at the panel seam of all outside closures. The fastener installed in the top hole must go through the panel seam and the corresponding hole of the adjacent outside closure.

Use urethane sealant to fill any voids around panel seam on upslope side of outside closure.

STEP 16 ERECTION SEQUENCE

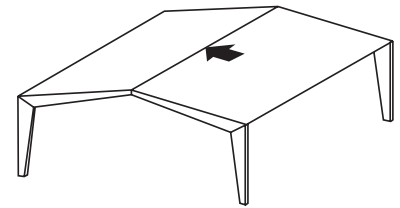

RIDGE-OUTSIDE CLOSURE/FLASHING

Apply Tri-Bead tape sealer to the top of the outside closure.

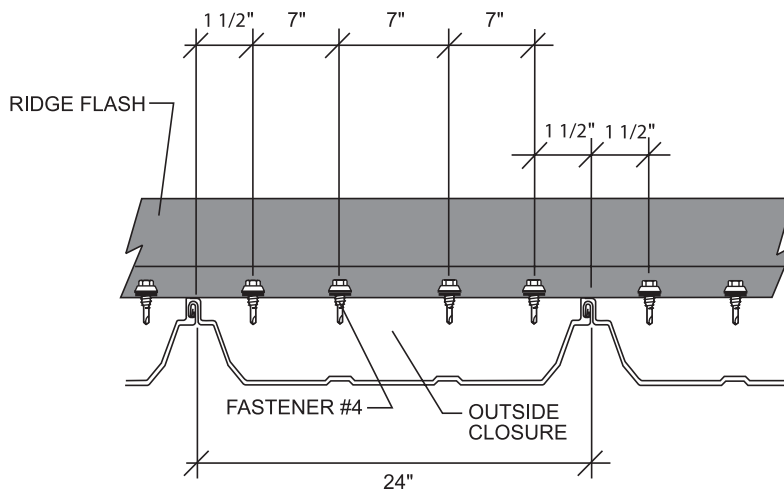
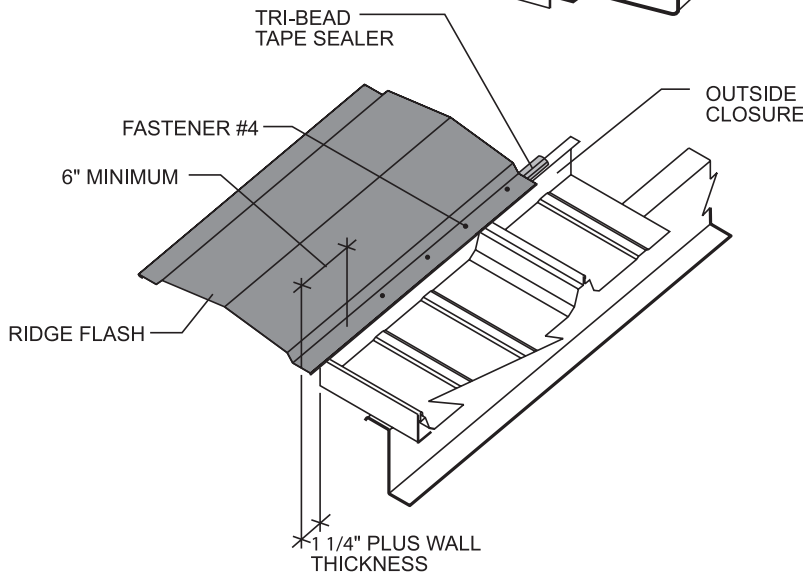
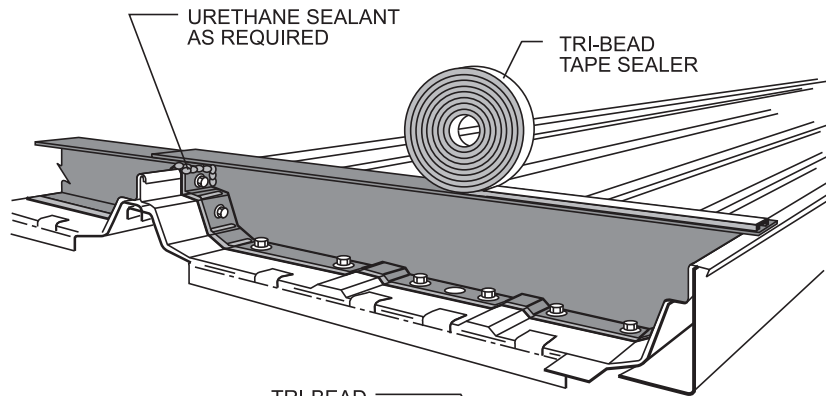

Install the ridge flashing starting and ending 1 1/4" plus wall thickness outside the steel line. Fasten the ridge flashing to the outside closures with Fastener #4. Install a fastener 1 1/2" from panel seam on both sides of panel. Install additional fasteners directly above minor ribs of panel. Four fasteners are required at each panel. Leave 6" unfastened on each end to allow for the rake trim to be installed later. **DO NOT FASTEN THROUGH THE LOCK OF THE STANDING SEAM.**

For floating peak box installation see page 63.

SPECIAL ERECTION SEQUENCE

RECOMMENDED ERECTION PRACTICES CORRECTING OUT-OF-PLANE SUBSTRUCTURE

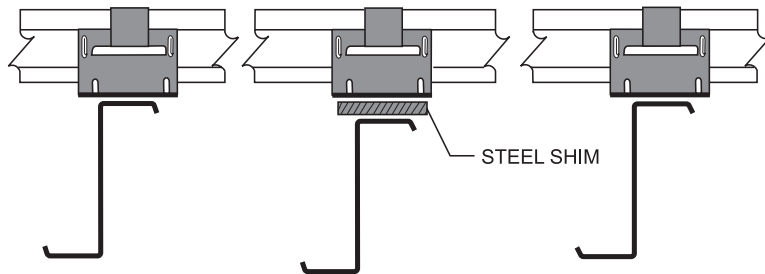

Occasionally a purlin may be encountered that is lower (out-of-plane) than those adjacent to it. When a clip is attached to this purlin, it will go down further than those adjacent to it, distorting the seam. This can cause the next panel sidelap to be difficult to snap together in this area. To compensate for this lower purlin, a steel shim may be placed under the clip to bring it up to the proper height (in plane). This shim should be no thicker than 1/4". If 1/4" is not enough, then structural modification will be necessary.

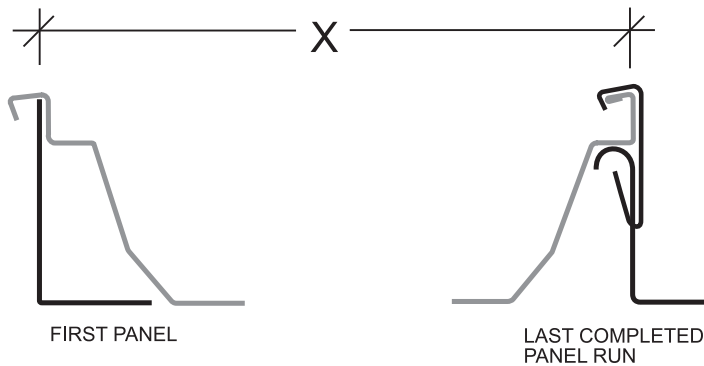

Avoid "stair-stepping" of the panels at the eave. This will cause problems engaging back-up plates at the endlap and ridge. This also will create the need to warp the cinch strap (if used) over the high rib forcing it to align with the holes in the adjacent panel.

Any "stripped out" fasteners at the endlaps or outside closures should be immediately replaced with Fastener #2A. Place a 1" long piece of Tri-bead tape sealer over the "stripped out" hole before installing Fastener #2A. This will allow the fastener threads to be coated with tape sealer and provide a good seal.

NEVER ALLOW PANELS TO COME INTO CONTACT WITH LEAD, COPPER, GRAPHITE, GASOLINE OR OTHER HARSH CHEMICALS AS THIS WILL VOID THE GALVALUME® WARRANTY.

CHECK ROOF FOR PANEL ALIGNMENT

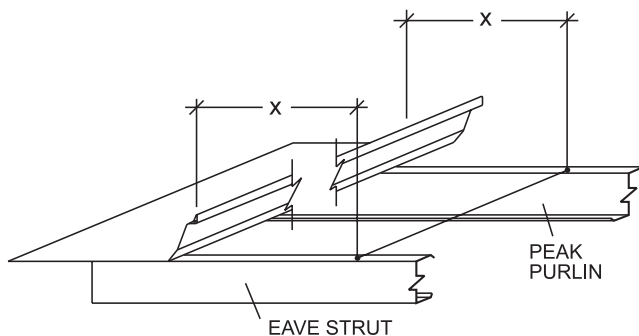

Check the roof every three or four runs for panel alignment as it is being erected. This can be accomplished by two different means.

1. Measure from the rake support to the seam of the last completed panel run. Take measurements at the ridge, eave, and all endlaps.
2. Attach a stringline to the eave plate and ridge purlin, running parallel to the rake support. The stringline should stay ahead of the work and can be moved across the roof as construction progresses. Measure from the stringline back to the last completed panel run. Take measurements at the ridge, eave, and all endlaps.

SPECIAL ERECTION SEQUENCE

RECOMMENDED ERECTION PRACTICES (CONTINUED) ADJUSTING PANEL WIDTH

NOTE

Do not adjust panel width more than 1/2" on any panel area.

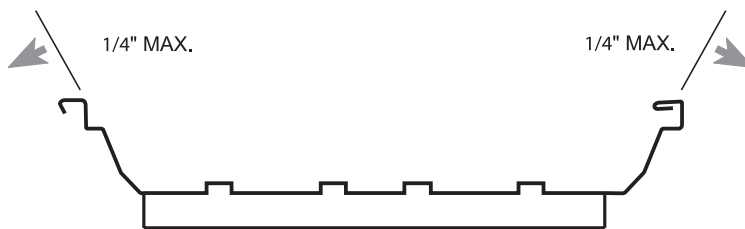
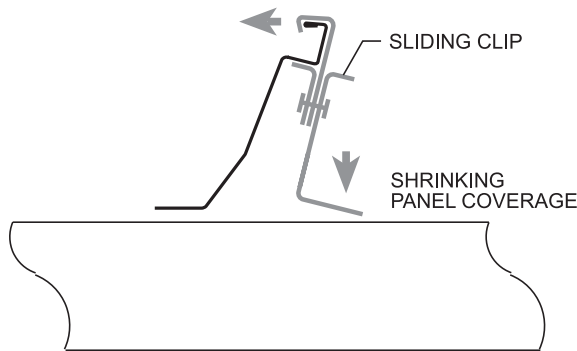
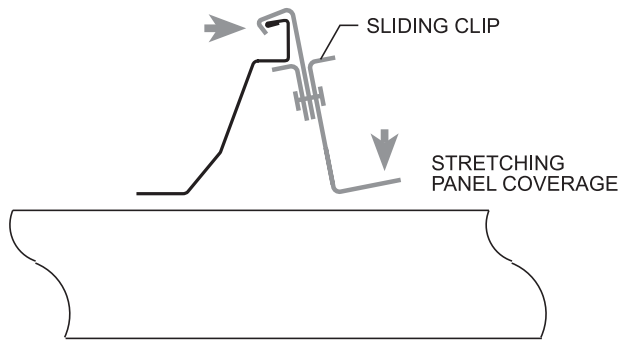

STRETCHING PANEL COVERAGE

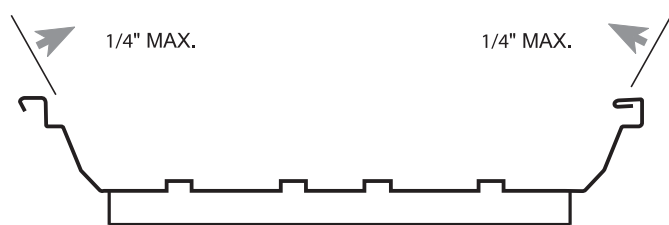

SHRINKING PANEL COVERAGE

SLIDING CLIP

To stretch panel coverage, install a sliding clip at the panel endlap or ridge with the base angled away from the panel. As the fastener is installed through the base of the clip and into the purlin, the clip base will rotate down to the purlin causing the top of the clip to move outward, stretching the panel coverage. Install the remainder of the clips as usual.

To shrink panel coverage, install a sliding clip at the panel endlap or ridge with the base angled toward the panel. As the fastener is installed through the base of the clip and into the purlin, the clip base will rotate down to the purlin causing the top of the clip to move inward, shrinking panel coverage. Install the remainder of the clips as usual.

FLOATING CLIP

To stretch panel coverage, bend the sides of the back-up plate out and install at endlap or ridge. Do not bend either side more than 1/4". Install clips as usual.

To shrink panel coverage, bend the sides of the back-up plate in and install at endlap or ridge. Do not bend either side more than 1/4". Install clips as usual.

SPECIAL ERECTION SEQUENCE

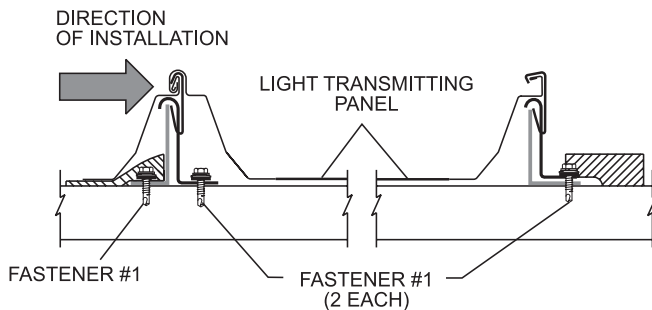
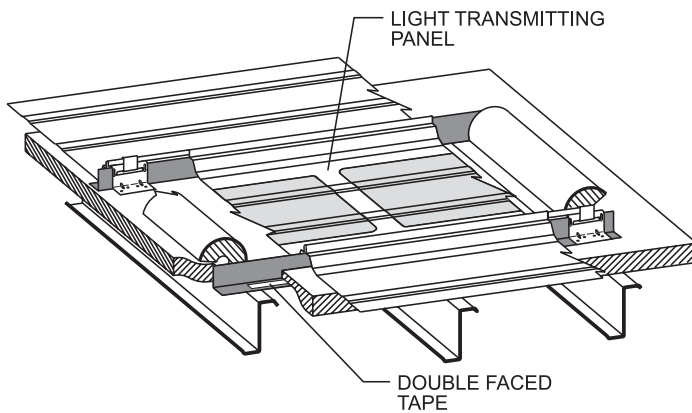
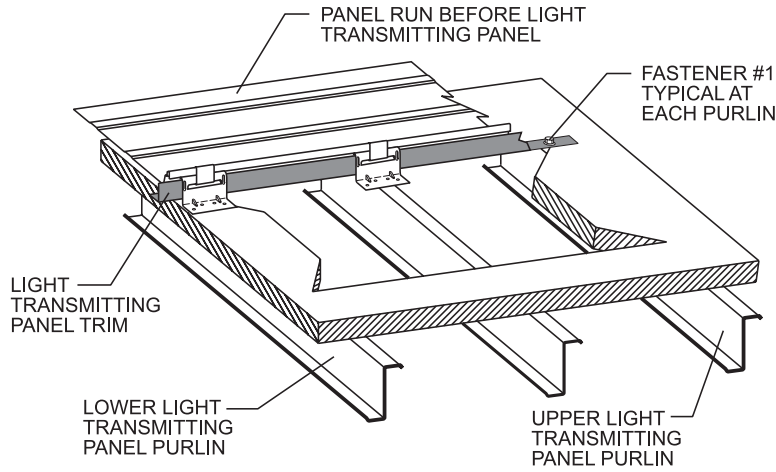

LIGHT TRANSMITTING PANEL TRIM INSTALLATION (OPTIONAL)

Light transmitting panel trim is available to cover the exposed insulation at the sides of the light transmitting panel opening. Two pieces of 2 1/4"x3 1/2"x10'-3" angle are required per light transmitting panel. This angle is designed to work with either the low or the high system. **THE 2 1/4" LEG IS TURNED UP FOR THE LOW SYSTEM AND THE 3 1/4" LEG IS TURNED UP FOR THE HIGH SYSTEM.**

INSTALLATION PROCEDURE

Install panels up to light transmitting panel run. Do not install clips on this run until first light transmitting panel trim piece is installed. Cut and remove insulation where light transmitting panel is to be located. Leave enough insulation at the top and bottom of the opening to be rolled back, allowing only the backing to be exposed. Place double faced tape on top of the horizontal leg of the trim to hold the insulation. Notch trim for back-up plates and install directly under male leg of last panel installed, running from lower light transmitting panel purlin to upper light transmitting panel purlin. Attach to purlins with Fastener #1. Install clips. Install lower light transmitting panel run panel. Leave upper-most clip off until next trim piece is installed. Fold insulation end tab under lower panel and install light transmitting panel. Fold upper insulation end tab above light transmitting panel. Fold upper insulation end tab above light transmitting panel and install upper light transmitting panel. Place double faced tape on next trim piece and notch for back-up plates. Install directly under male leg of light transmitting panel and clip all panels down.

CAUTION

The following are examples of conditions that may cause condensation on light transmitting panels: (A) Projects where outside winter temperatures below 40°F are anticipated and where average winter interior relative humidity of 45% or greater is expected. (B) Building usages with high humidity interiors, such as indoor swimming pools, textile manufacturing operations, food paper or other wet-process industrial plants. (C) Construction elements that may release moisture after the roof is installed, such as interior concrete and masonry, plaster finishes and fuel burning heaters. Manufacturer is not responsible for determining if condensation will be an issue on any particular application.

SPECIAL ERECTION SEQUENCE

RIDGE VENTILATOR INSTALLATION

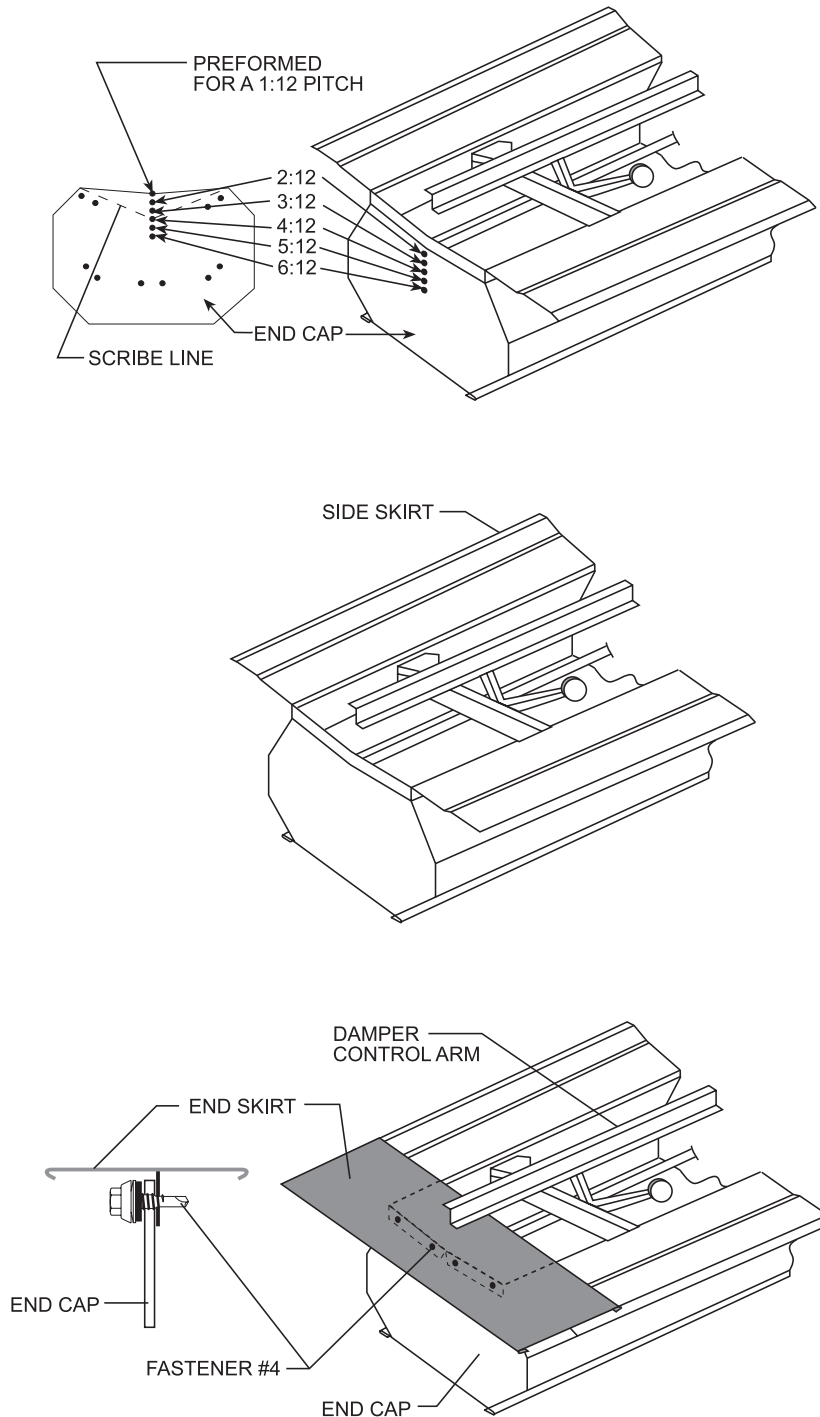

NOTE

The manufacturer does not recommend the use of a ridge ventilator on standing seam roof systems. Sidewall or endwall exhaust fans or other ventilating methods should be considered. These details are for your convenience only. **Do not use ridge ventilators on any roof over 200' in width or with a slope less than 1:12 or greater than 6:12.**

Turn ventilator over and place gently on its top. Note that the end cap is pre-formed for a 1:12 roof pitch. The five bench mark dots represent 2:12, 3:12, 4:12, 5:12 and 6:12 roof pitches. Draw a line between indicated corners and the appropriate dot for the roof pitch. Cut and remove that portion of the end cap. On 5:12 and 6:12 roof pitches see vent manufacturer's special instructions for the installation of the vent skirt. The end cap is now ready to receive the end skirt.

Position end skirt onto end cap. Be sure the down-turned angle of the end skirt is inside of and up against the end cap. Attach end skirt to ventilator end cap with Fastener #4 in four places.

SPECIAL ERECTION SEQUENCE

RIDGE VENTILATOR INSTALLATION (CONTINUED)

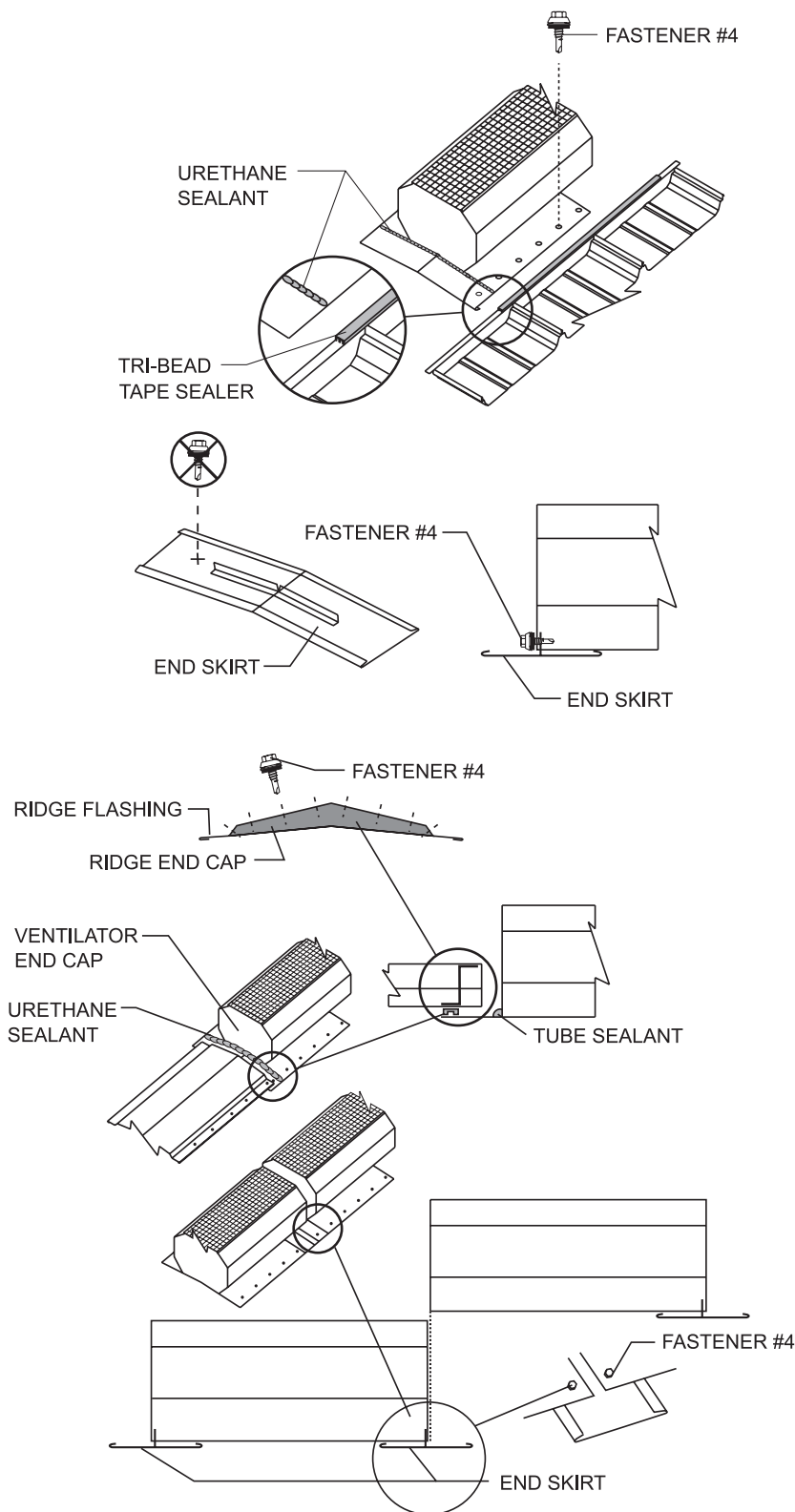

Apply Tri-Bead tape sealer to top of outside closures. Install ventilator making sure to center in opening. Attach ventilator to outside closures with Fastener #4 on 6" centers. Use urethane sealant to seal between the outside of the ventilator and the end skirt.

Install the ridge flashing as in Step 14, except for those pieces on either side of ventilator. These will lay on top of, and seal to, the ventilator end skirt with a ridge end cap. Use Tri-Bead tape sealer to seal the ridge end cap to the ridge flashing and the end skirt. Use Fastener #4 to install the end cap. Six fasteners are required to tie the end cap to the ventilator end skirt. Eight fasteners are required to tie the end cap to the ridge flashing.

For continuous ventilators, install end skirts on both ends of the first ventilator and one end of all following ventilators. Attach ventilator to outside closures as outlined above. Install an additional Fastener #4 through the corner of the side skirt and into the end skirt.

Do not connect more than 4 vents to the same linkage.

SPECIAL ERECTION TECHNIQUES

12" X 10'-0" RIDGE VENTILATORS

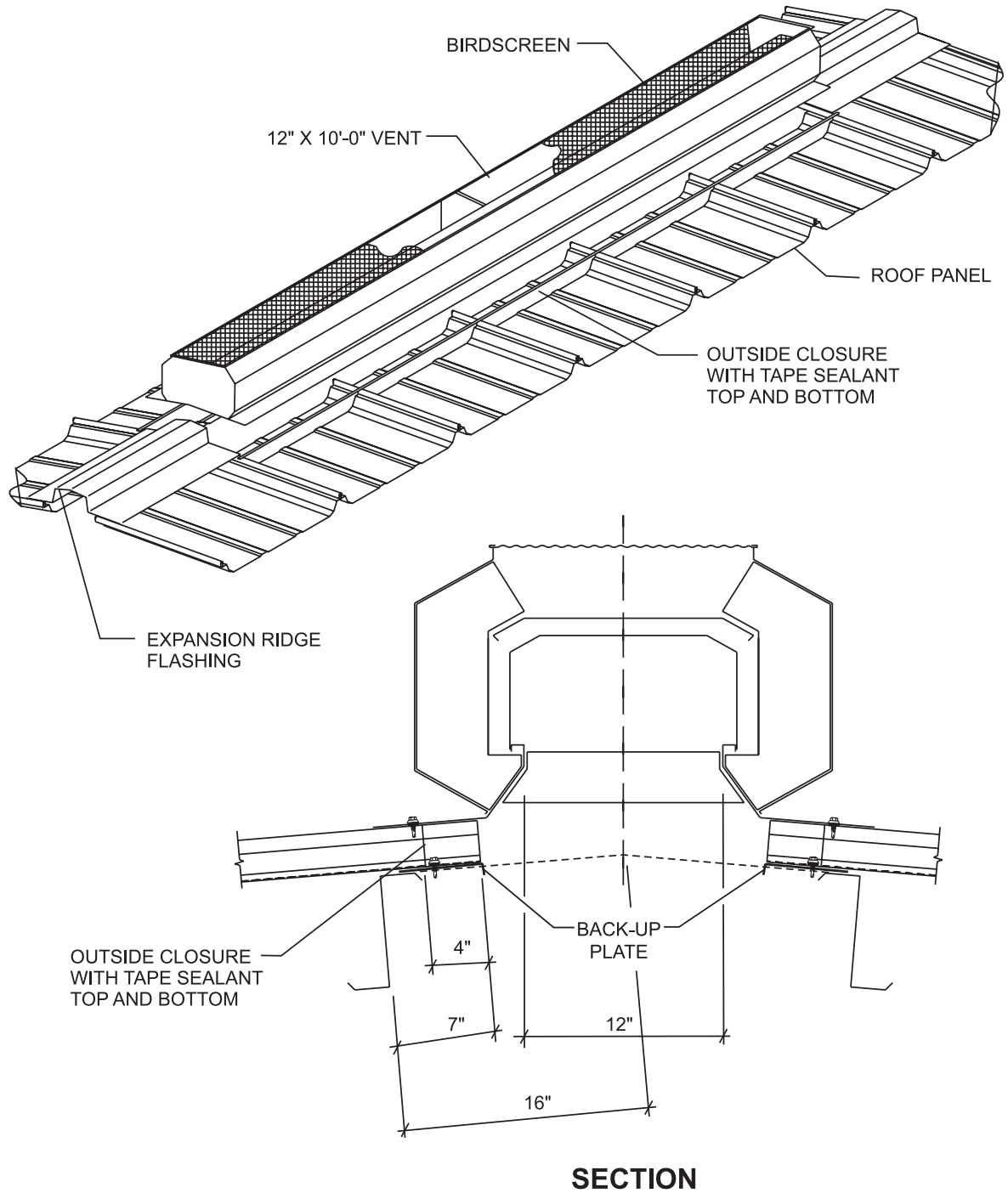

SPECIAL ERECTION TECHNIQUES

OUTSIDE CLOSURE LOCATION AT 12" x 10'-0" RIDGE VENT

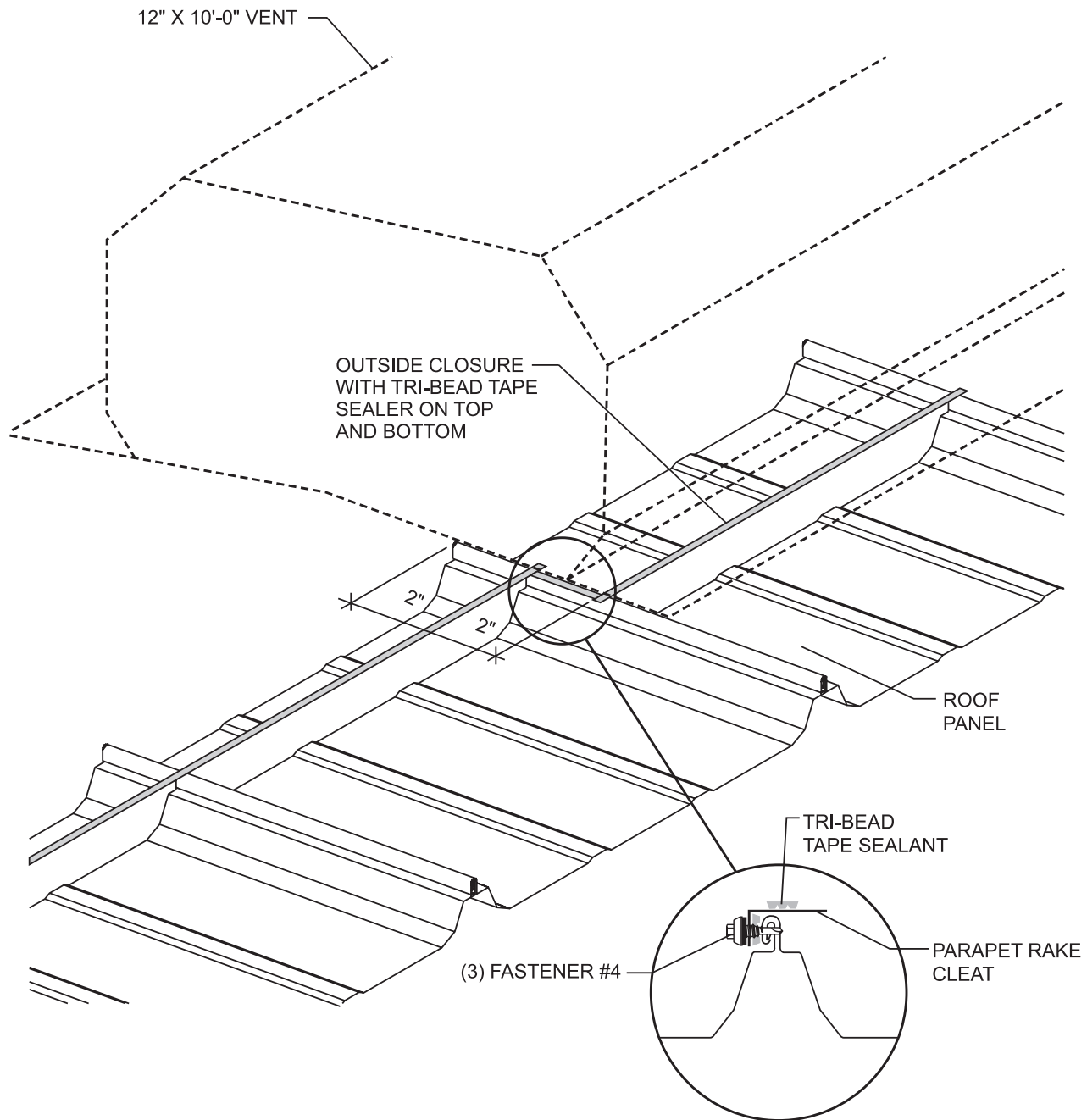

ERECTION SEQUENCE

RIDGE VENTILATORS (12" X 10'-0")

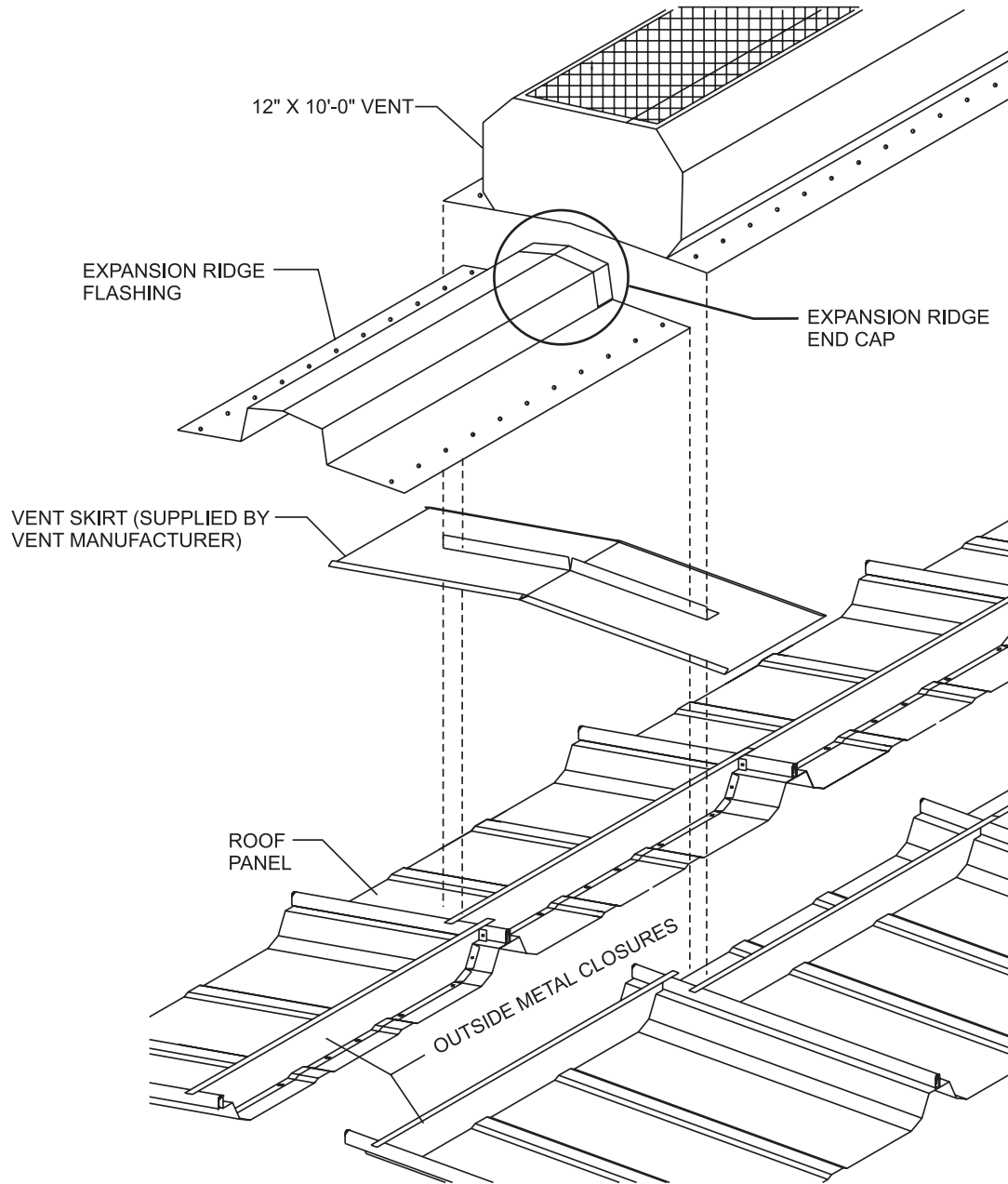

ERECTION SEQUENCE

9" x 10'-0" RIDGE VENTILATORS

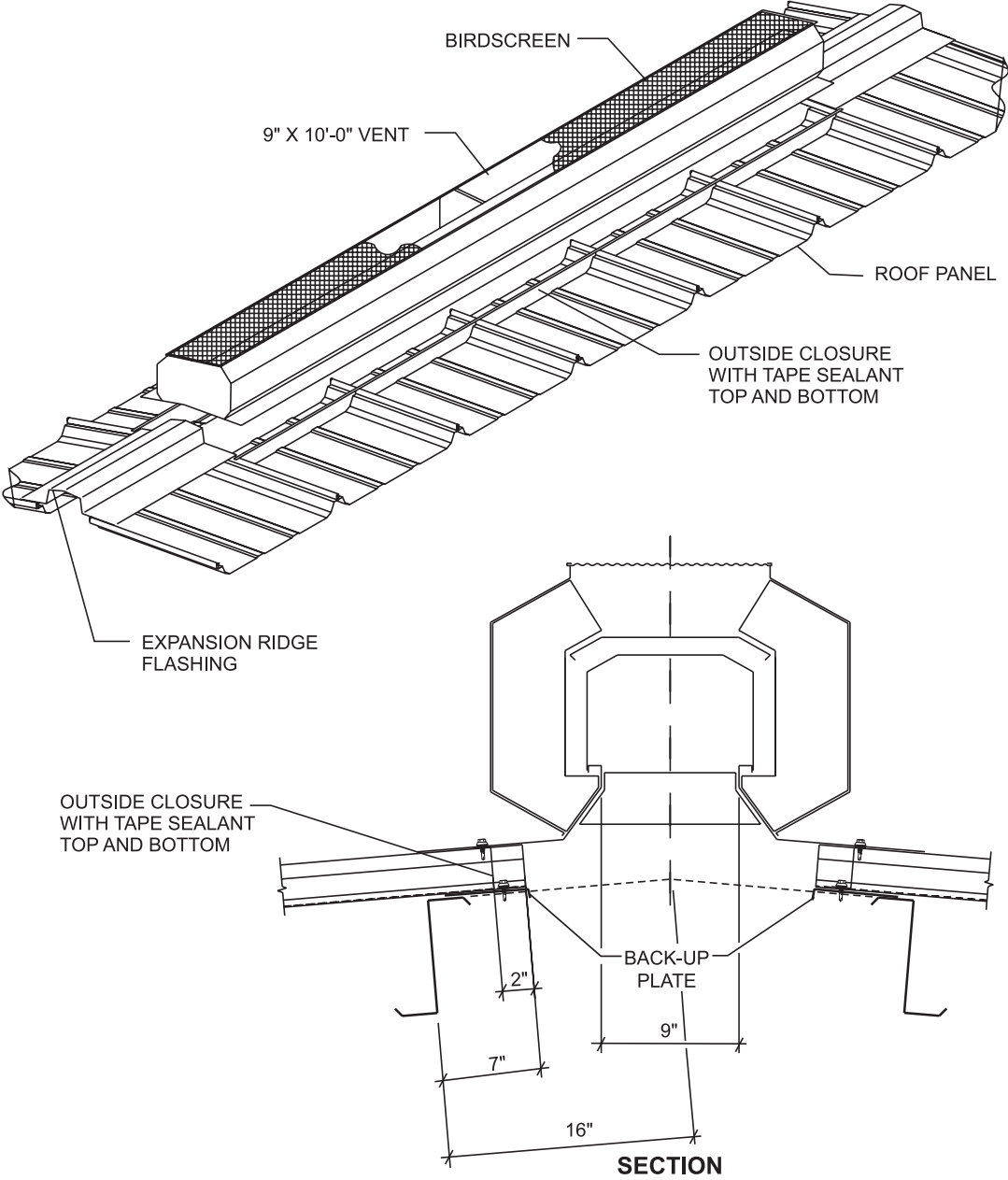

ERECTION SEQUENCE

OUTSIDE CLOSURE LOCATION AT 9" x 10'-0" RIDGE VENT

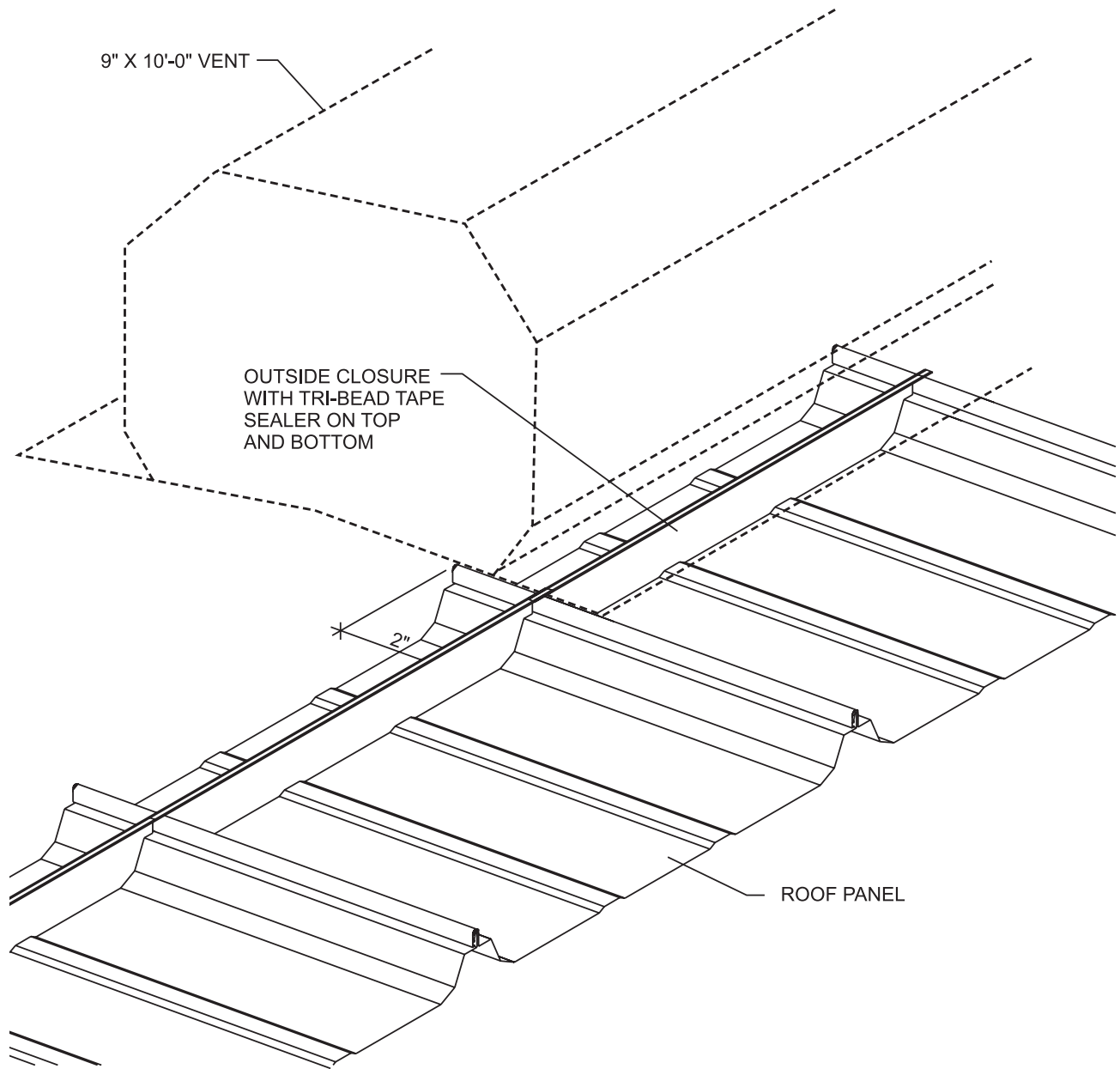

ERECTION SEQUENCE

RIDGE VENTILATORS (9" x 10'-0")

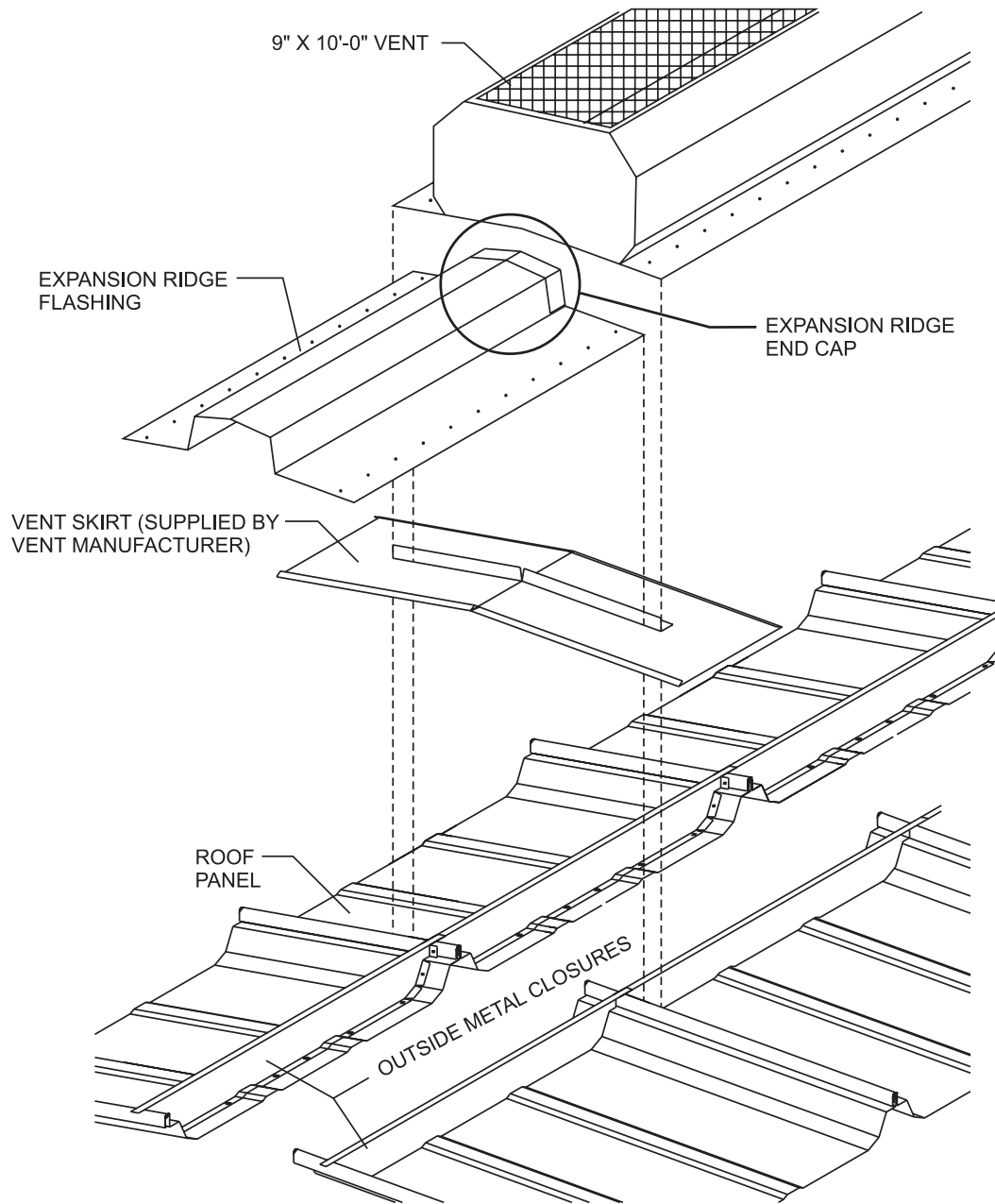

ERECTION SEQUENCE

10" VENTED RIDGE (12" PEAK PURLIN SPACING)

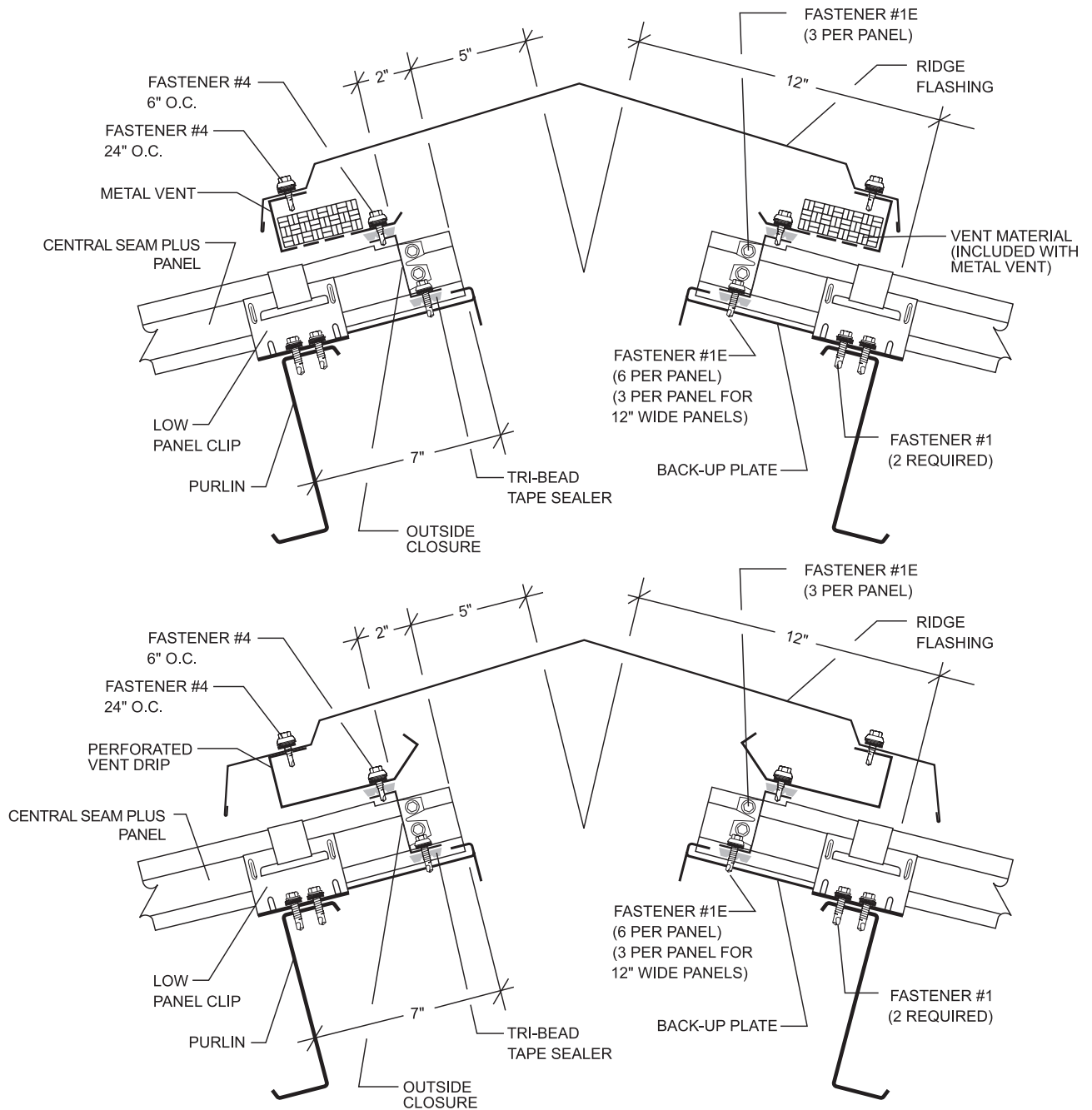

ERECTION SEQUENCE

18" VENTED RIDGE (16" PEAK PURLIN SPACING)

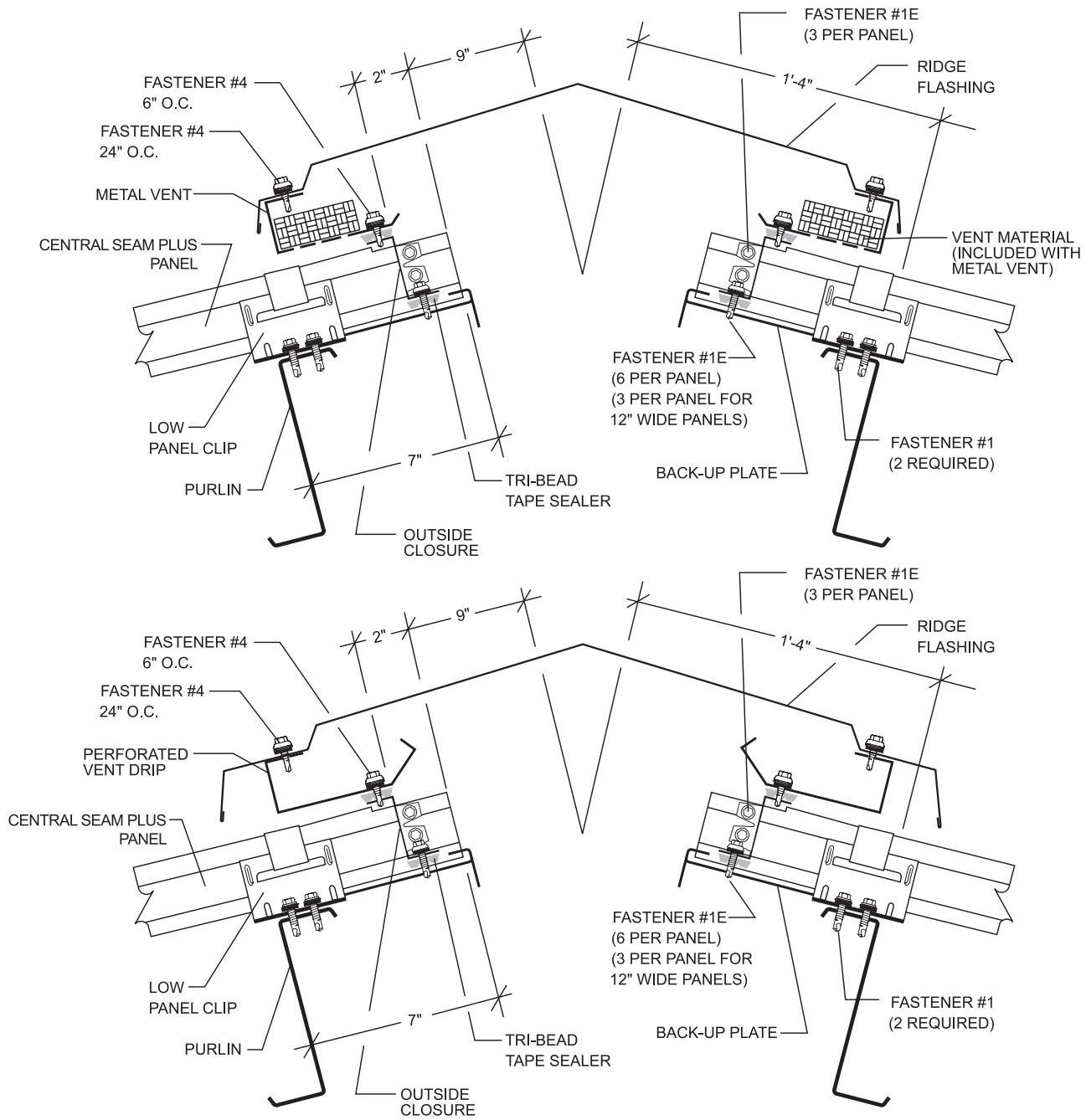

ERECTION SEQUENCE

MID-SLOPE FIXED CONDITION

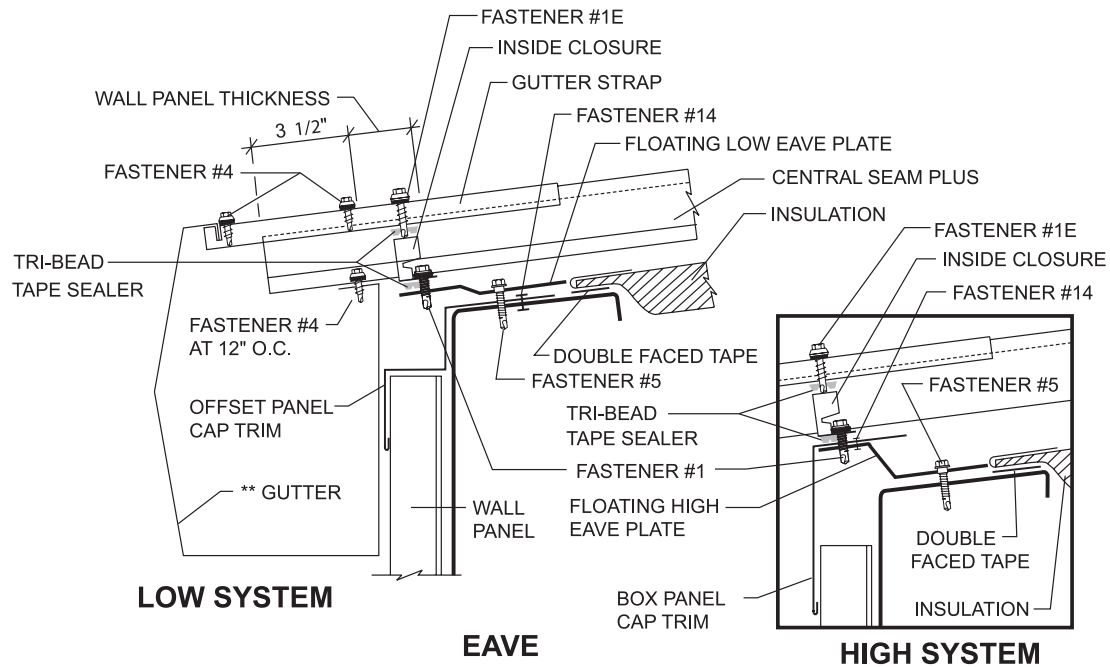
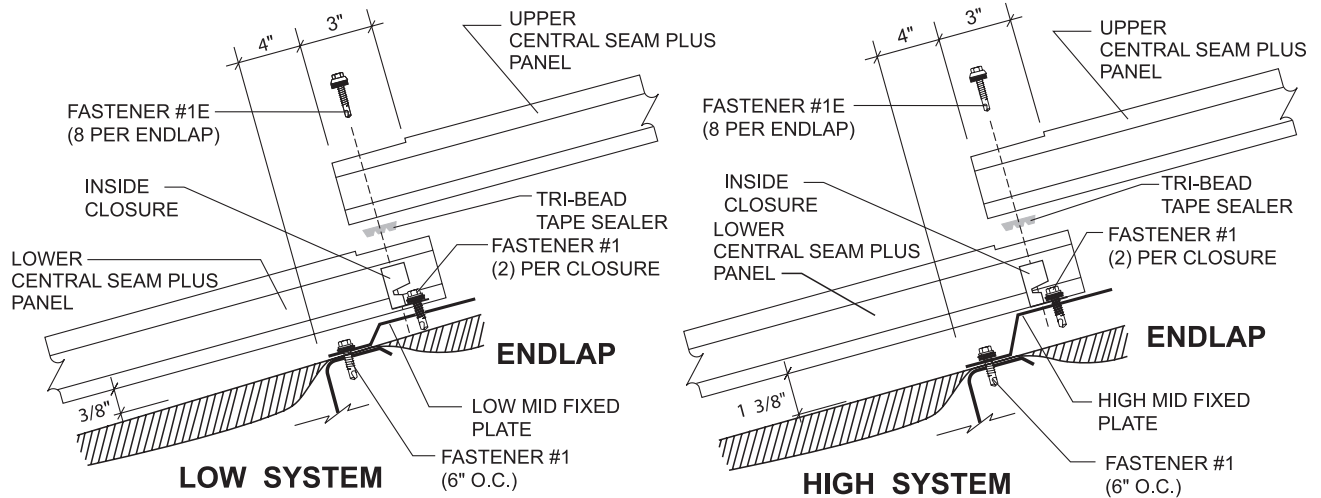

**Profile May Vary

NOTES:

1. This special detail is for use when a panel run exceeds the thermal movement capabilities of the panel clip. Floating clips have a maximum movement of 1" in each direction. Articulating clips have a maximum movement of 1 1/4" in each direction. Thermal calculations must be performed for each project to ensure that the thermal movement of the roof will not exceed the design of the clips and slot in the floating eave plate.
2. A positive panel attachment is made at the mid-point in the panel run allowing for thermal movement to the eave and ridge.
3. The standard floating ridge condition must be used in conjunction with this special eave detail.
4. **The floating eave plate must be used to allow for panel movement at the eave.**

ERECTION SEQUENCE

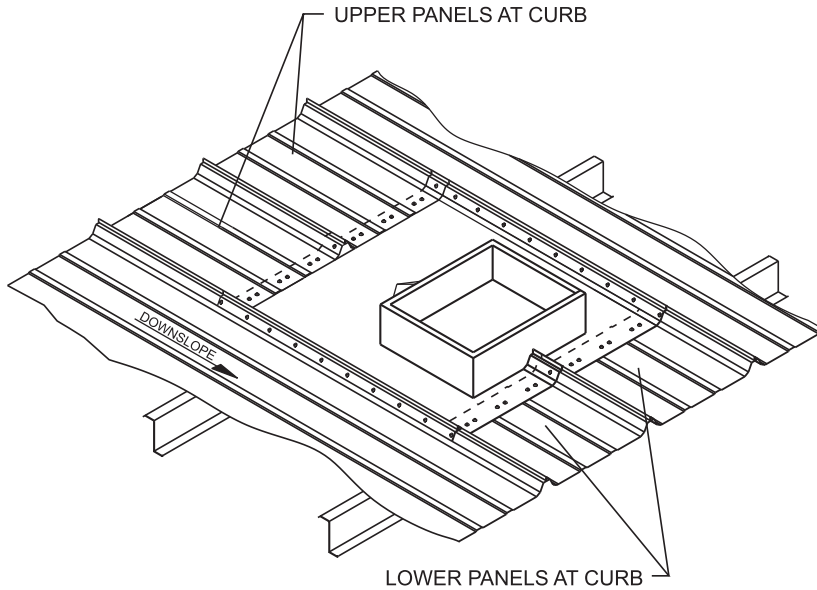

ROOF CURB INSTALLATION

The manufacturer recommends that only one-piece aluminum curbs be used on its standing seam roof systems. The curb flange is constructed to match the configuration of the panel. The side flange extends to the next natural seam in the roof panel and conforms to the seam configuration. Cap strips, furnished by the curb manufacturer, secure the curb to the roof panels. The roof curb is installed under the roof panels on the upslope end and on top of the roof panels on the downslope end. Support framing should be installed before curb installation. **Back-up plates (for the roof panels at the down slope end of the curb), a floating eave plate (for the upslope end of the curb), long-life fasteners and Triple Bead tape sealer must be ordered for each curb.**

These curbs may be installed as the roof is being installed or after the roof has been installed. Since the curb sides are an integral part of the roof seam, the curb must align with the roof panel seams. If the curb can be shifted up to 12" to either side, the curb can be pre-ordered and be installed with the roof panels or installed after the roof is in place. If the curb placement is critical, install the curb support framing at the desired location and roof over it. Measure the panel rib locations in reference to the required curb opening and order the roof curb for each location. The curbs can then be installed in each location, ensuring an exact fit.

ROOF CURB CROSS SECTION

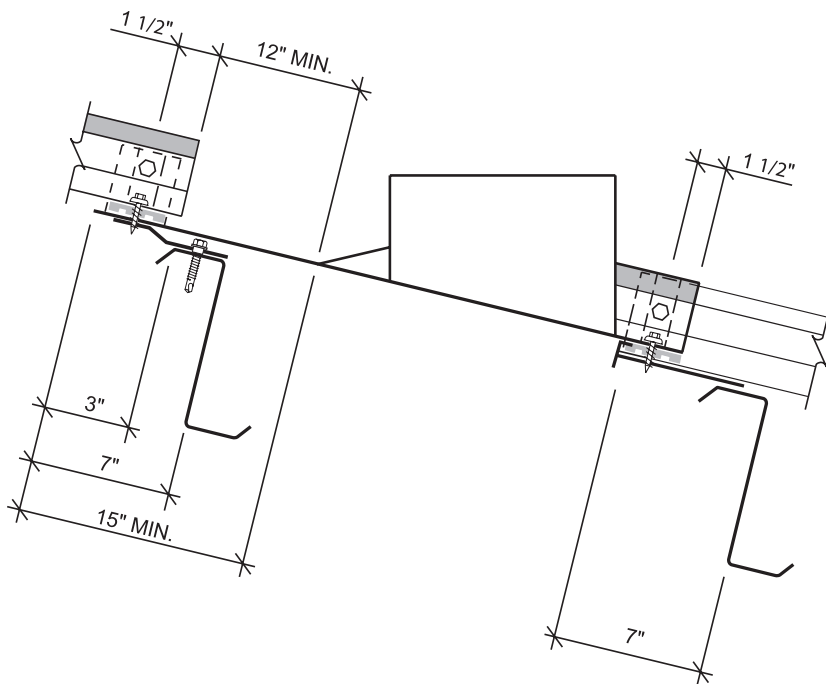

ATTENTION

All curbs must be installed over support framing, supplied by the metal building manufacturer or the curb supplier. Support framing must be properly located to provide "endlap" conditions at the upslope and downslope ends of the curb. Refer to Roof Curb Cross Section for critical dimensions.

ERECTION SEQUENCE

INSTALLING CURB WITH ROOF (Continued)

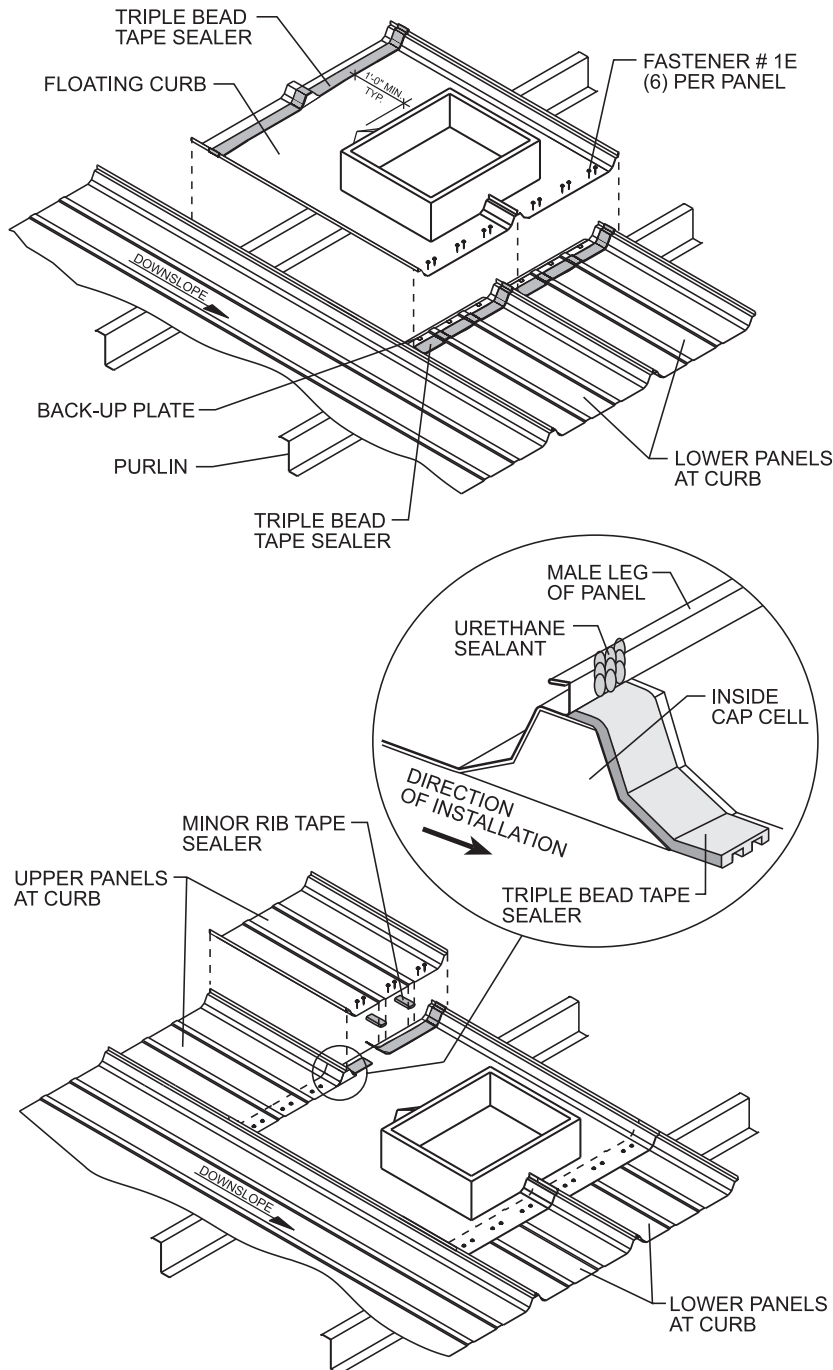

Install the roof curb on top of the lower roof panels and the curb support framing. Do not attach the curb to the support framing as this may prevent the curb from floating with the roof. Fasten the down slope end of the roof curb to the lower roof panels and back-up plates with Fastener #1E as at a standard endlap. This will require six fasteners in the pan of the panel and one in each trapezoid for a total of eight fasteners per panel. Fasteners must go through the Triple Bead tape sealer.

Install Triple Bead tape sealer across the width of the upslope end of the roof curb. Use the down slope end of the inside cap cell, which is welded to the roof curb, as a guide for placement of the tape sealer.

Apply minor rib tape sealer to the underside of the minor ribs on the down slope end of the upper panels. Install the upper panels with Fastener #1E as at a standard endlap. This will require six fasteners in the pan of the panel and one in each trapezoid for a total of eight fasteners per panel. Fasteners must go through the Triple Bead tape sealer. The down slope edge of these panels should be flush with the down slope edge of the inside cap cell. Apply urethane sealant to the male leg of all panels directly over the inside cap cell. This will prevent water infiltration through the end of the panel seam.

ERECTION SEQUENCE

INSTALLING CURB WITH ROOF

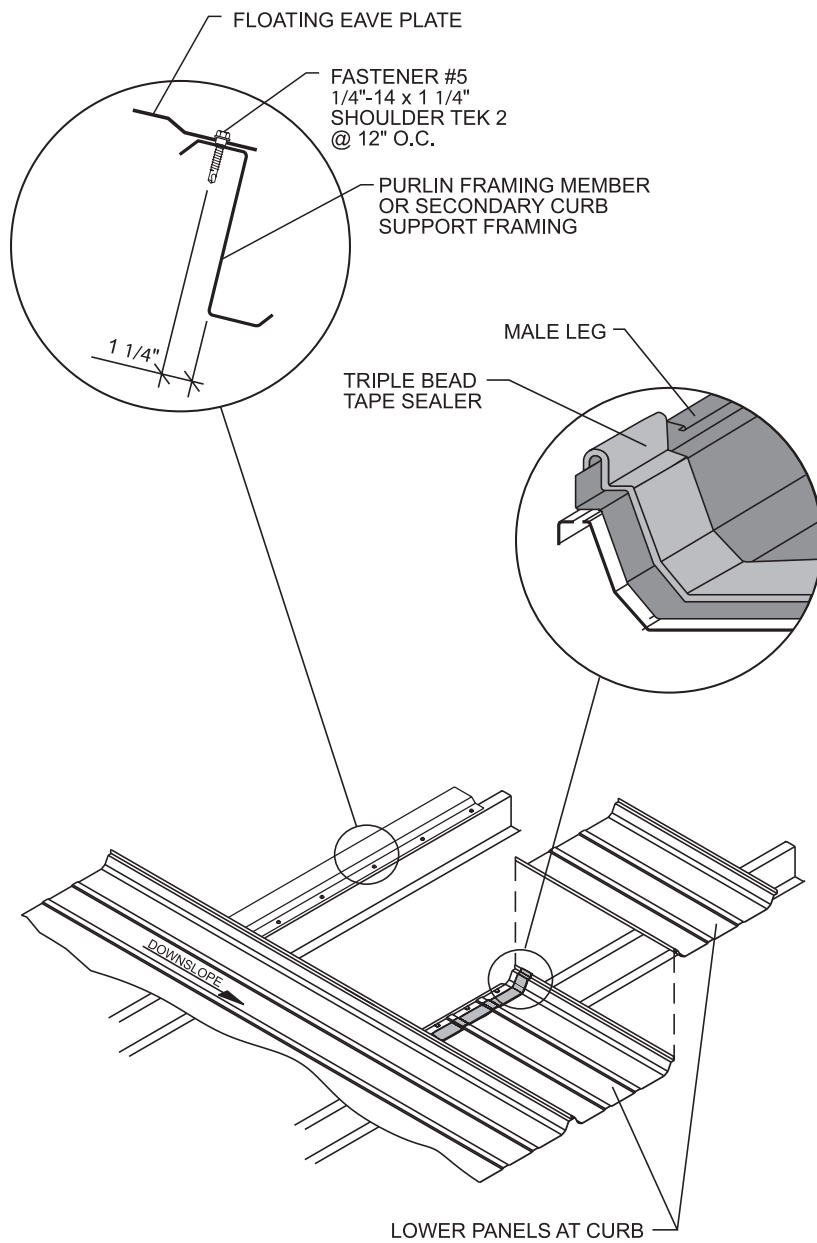

Install curb support framing at curb location. Install full length roof panels up to curb location. Install lower panels at downslope end of curb. If the lower panels are field cut to length, you must (1) cut the downslope end, leaving a factory cut at the curb end or (2) if the curb end of the panel is field cut, notch the male leg as it is done in the factory. Place Triple Bead tape sealer across the full width of each panel as it is installed. To determine how far down on the panel to place the tape sealer, temporarily lay the curb in place and mark the down slope edge of the curb on the first panel. This will give you a reference point as to how far down slope to place the tape sealer. It is critical that the tape sealer be installed across each panel individually so that the tape sealer can be placed over the male leg. This will provide a seal in the panel seam when the next panel is installed. Install back-up plates onto each of the lower panels.

ERECTION SEQUENCE

INSTALLING CURB WITH ROOF (Continued)

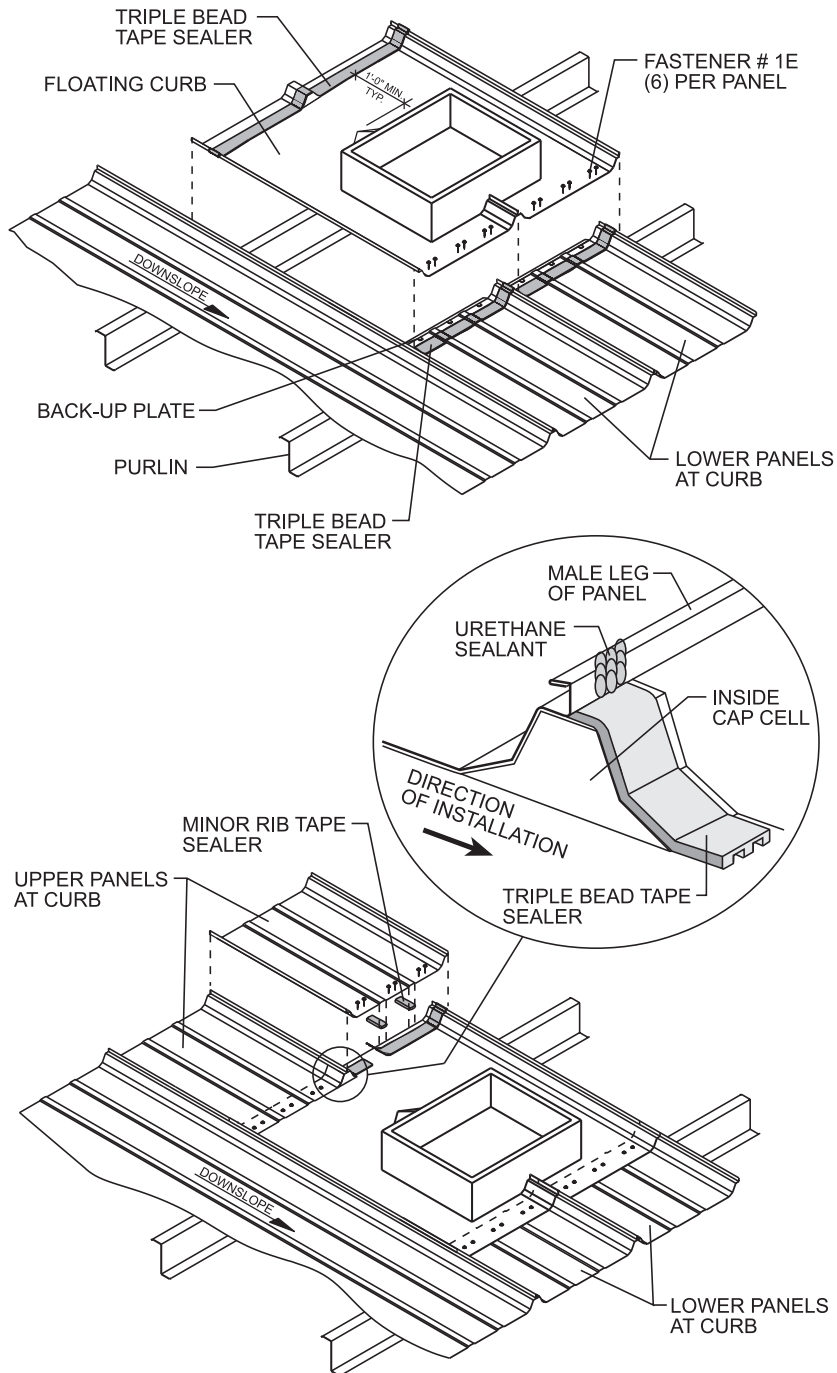

Install the roof curb on top of the lower roof panels and the curb support framing. Do not attach the curb to the support framing as this may prevent the curb from floating with the roof. Fasten the down slope end of the roof curb to the lower roof panels and back-up plates with Fastener #1E as at a standard endlap. This will require six fasteners in the pan of the panel and one in each trapezoid for a total of eight fasteners per panel. Fasteners must go through the Triple Bead tape sealer.

Install Triple Bead tape sealer across the width of the upslope end of the roof curb. Use the down slope end of the inside cap cell, which is welded to the roof curb, as a guide for placement of the tape sealer.

Apply minor rib tape sealer to the underside of the minor ribs on the down slope end of the upper panels. Install the upper panels with Fastener #1E as at a standard endlap. This will require six fasteners in the pan of the panel and one in each trapezoid for a total of eight fasteners per panel. Fasteners must go through the Triple Bead tape sealer. The down slope edge of these panels should be flush with the down slope edge of the inside cap cell. Apply urethane sealant to the male leg of all panels directly over the inside cap cell. This will prevent water infiltration through the end of the panel seam.

ERECTION SEQUENCE

INSTALLING CURB WITH ROOF (Continued)

After all upper panels have been installed, install full length panel at side of curb. This panel will engage the male leg of the adjacent upper and lower panels. The female leg of this full length panel will overlap the leg of the roof curb.

Cap strips will be installed, full length, along both sides of the curb to seal the curb to the roof panels. Turn the cap strips upside down and install Tri Bead tape sealer and along the full length of the cap strip. Lower edge of tape sealer should be flush with the lower edge of the cap strip. Apply a generous bead of urethane sealant at both ends of the seam portion of the cap strip. Install each cap strip over the curb/roof panel sidelap with the lower end of the cap strip even with the lower end of the curb. Force the cap strip down tightly to the curb/roof panel sidelap and fasten both sides with Fastener #4 at 6" on center.

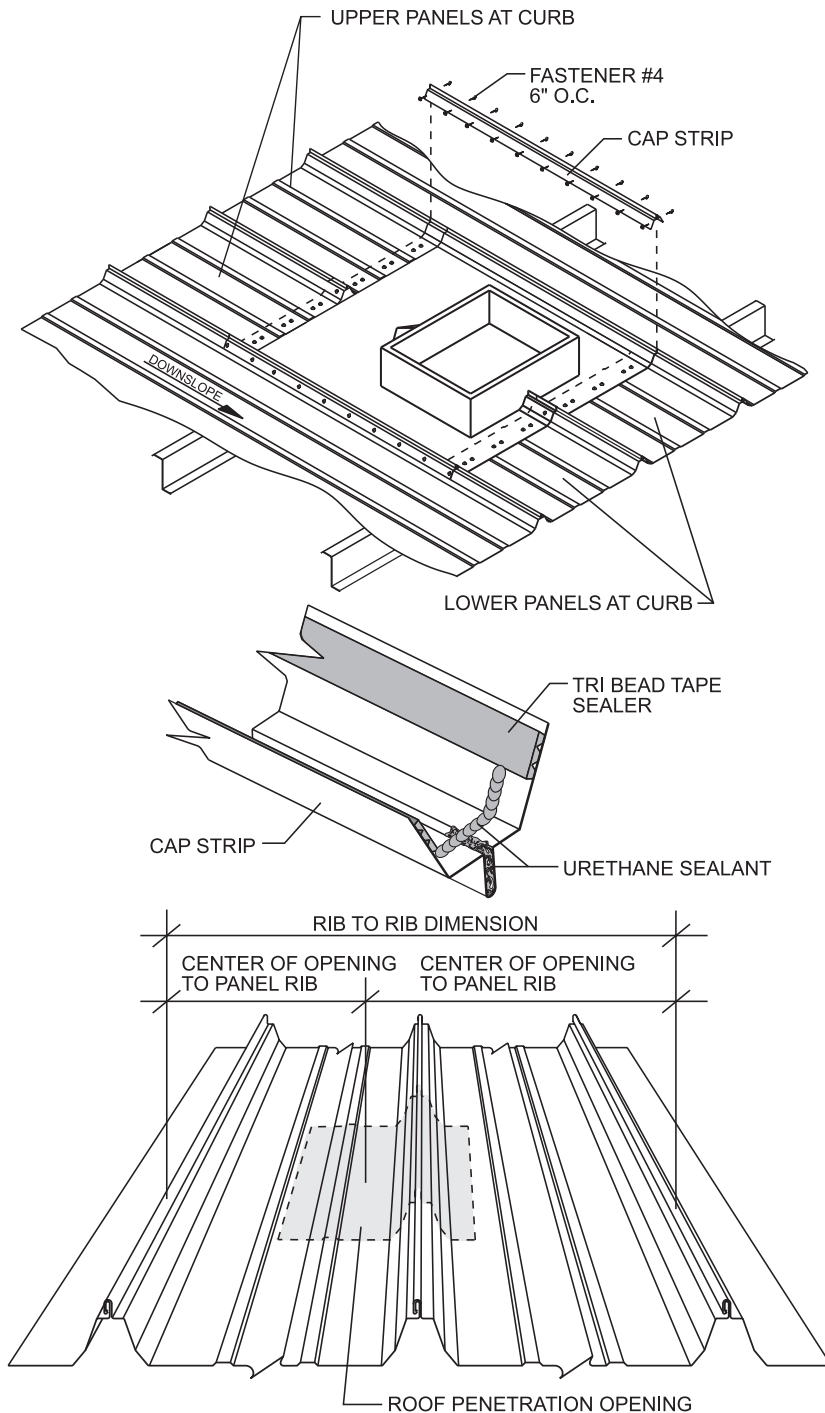

INSTALLING CURB AFTER ROOF INSTALLATION

When curbs must be installed in an exact location, the curb support framing can be installed before beginning the roof. When a curb is to be added after the roof is installed, the curb framing must be installed from below the roof after the roof panels have been cut for installation of the curb.

After roof is installed, identify the exact location for the curb. Measure from the center of the required opening to the nearest panel rib in each direction. Also, determine how many panels will be affected by the curb (minimum clearance between vertical wall of curb opening and panel rib is 6") and measure from center of rib of first panel affected to center of rib of last panel affected (if 24" panel module was not held during roof installation, this dimension will be critical). This information will be required to fabricate the curb so that it will fit the location exactly.

ERECTION SEQUENCE

INSTALLING CURB AFTER ROOF (Continued)

Cap strips will be installed, full length along both sides of the curb to seal the curb to the roof panels. Turn the cap strips upside down and install Tri Bead tape sealer to both sides and along the full length of the cap strip. Lower edge of tape sealer should be flush with the lower edge of the cap strip. Apply a generous bead of urethane sealant at both ends of the seam portion of the cap strip. Install each cap strip over the curb/roof panel sidelap with the lower end of the cap strip even with the lower end of the curb. Force the cap strip down tightly to the curb/roof panel sidelap and fasten both sides with Fastener #4 at 6" on center.

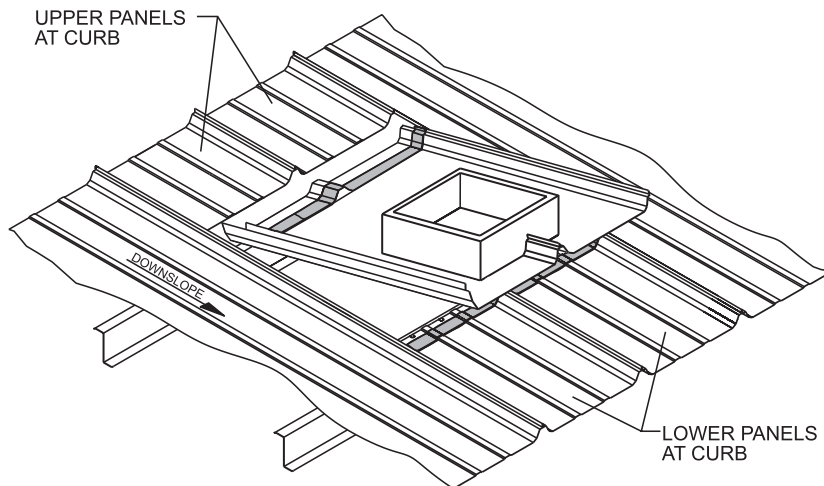
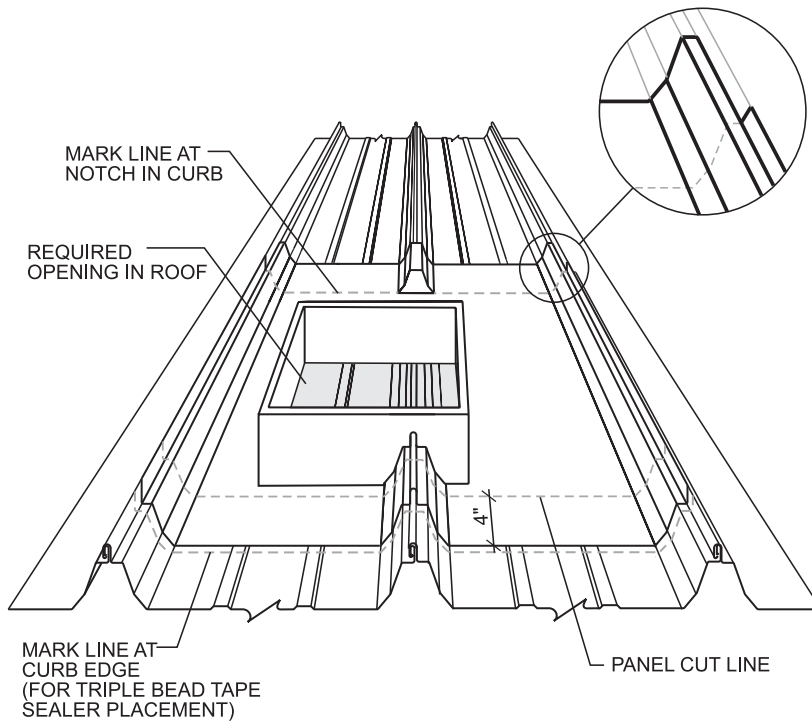

ERECTION SEQUENCE

INSTALLING CURB AFTER ROOF (Continued)

Once curb is ready to be installed, lay curb on roof and align opening in the curb with the exact location the opening is required in the roof. At the up slope end of the roof curb, the roof panels will be cut on a line even with the beginning of the notch at the vertical leg on each side of the roof curb. Secondly, trace a line along the down slope edge of the roof curb. The roof panels will be cut on a line 4" up slope from this line.

Cut roof panels from rib of first panel affected by curb, to rib of last panel affected, along the top and bottom cut lines previously marked.

At the down slope end of the roof opening, install back-up plates onto the ends of the cut roof panels and Triple Bead tape sealer across the full width of these roof panels. The down slope edge of the tape sealer should be on the line previously traced along the downslope edge of the roof curb. The up slope edge of the tape sealer will be approximately 1 1/2" from the end of the cut panel.

Apply Triple Bead tape sealer across the full width of the up slope end of the roof curb. The down slope edge of the tape sealer will align with the down slope edge of the inside cap cells welded to the roof curb.

Install the roof curb under the roof panels at the up slope end and on top of the panels at the down slope end. This will require that you lift the roof panels up slightly at the up slope end to allow the upper flange of the roof curb to slide under the panels. Spray some soapy water on the tape sealer to prevent it from sticking to the roof panels until you have the curb completely in place.

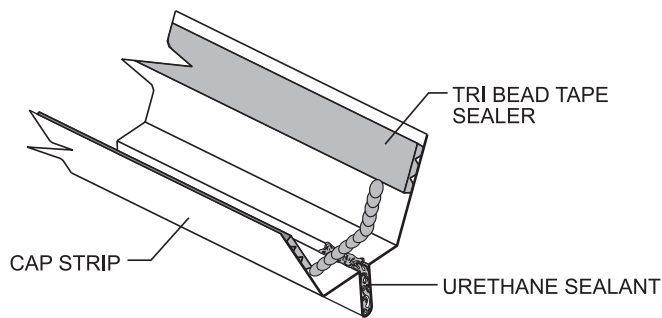
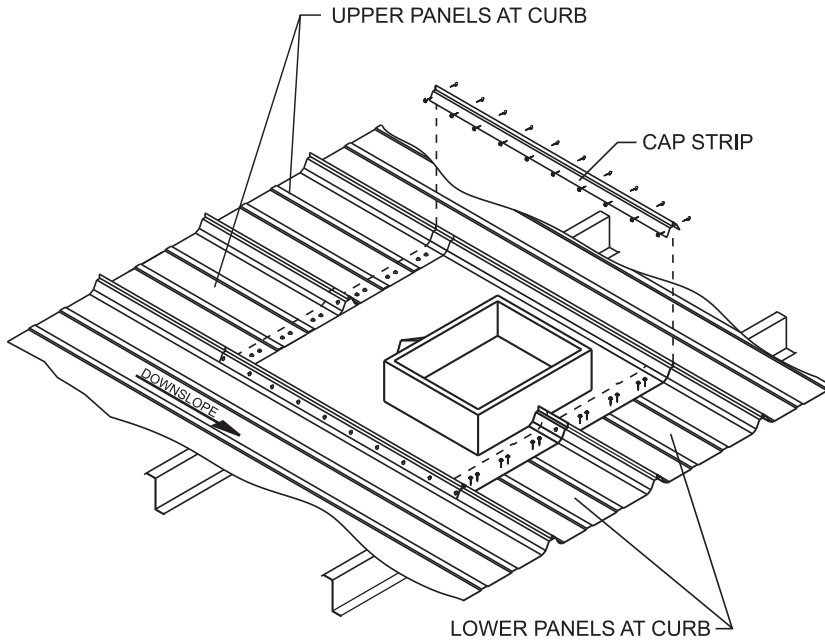

ERECTION SEQUENCE

ROOF CURB CROSS SECTION

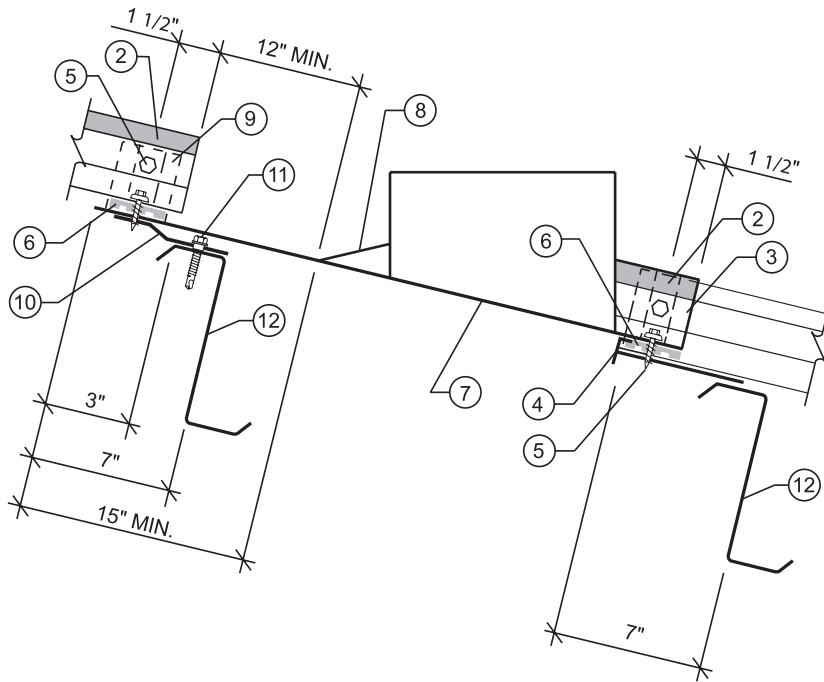

ROOF CURB CROSS SECTION

1. Central Seam Plus Panel
2. Urethane Sealant
3. Outside Cap Cell
4. Back-up Plate
5. Fastener #1E
6. Triple Bead Tape Sealer
7. Roof Curb
8. Water Diverter
9. Inside Cap Cell
10. Floating Eave Plate
11. Fastener #5
12. Purlin Framing Member or
Secondary Curb Support Framing

ROOF CURB ISOMETRIC

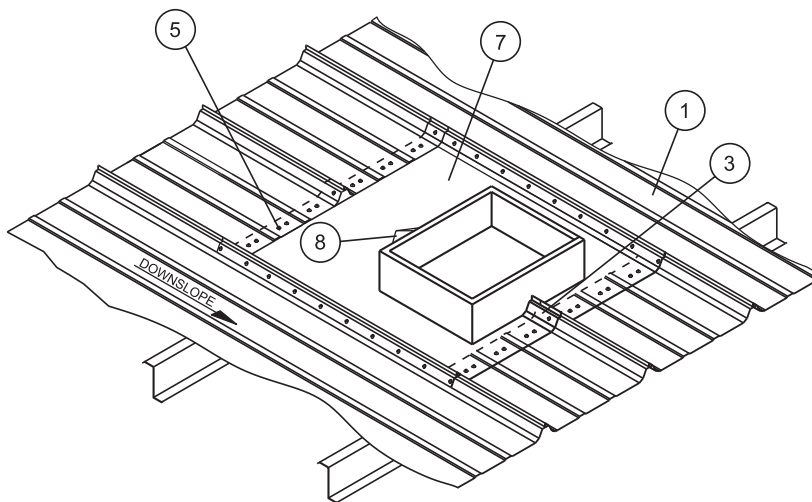

SPECIAL ERECTION TECHNIQUES

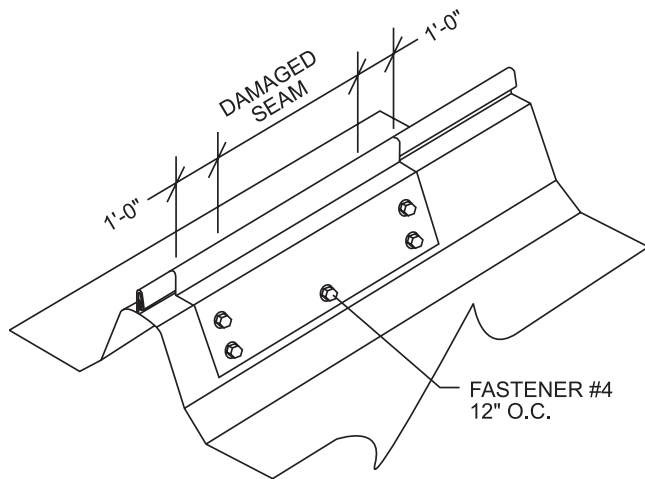

GUIDELINES FOR INSTALLING REPAIR CAP ON DAMAGED Central Seam Plus SEAMS

Repair cap must be fabricated from the same gauge material and have the same finish as roof panels and must extend a minimum of 12" above and below the damaged area.

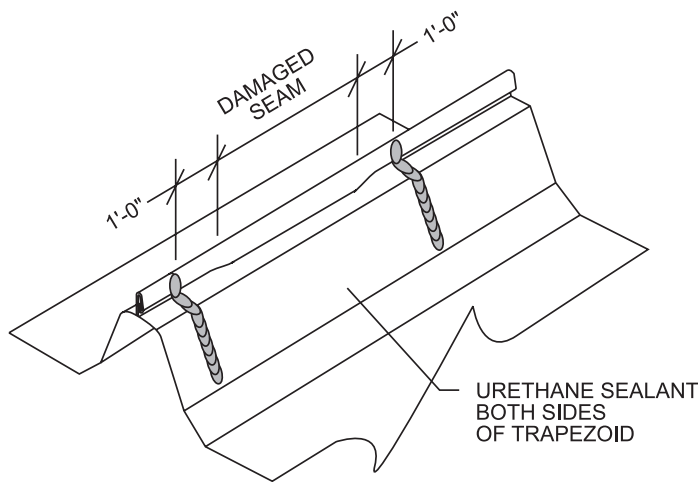

Install a continuous run of Tri-Bead tape sealer to the inside of both legs of the repair cap. Place lower edge of tape sealer approximately 1/4" up from bottom of legs. Fill seam portion of repair cap with urethane sealant. At each end of repair cap, apply a 3/8" bead of sealant across the inside cross section of the repair cap.

Push repair cap down onto panel and fasten with Fastener #4 - 4" O.C. Fasteners must go through tape sealer.

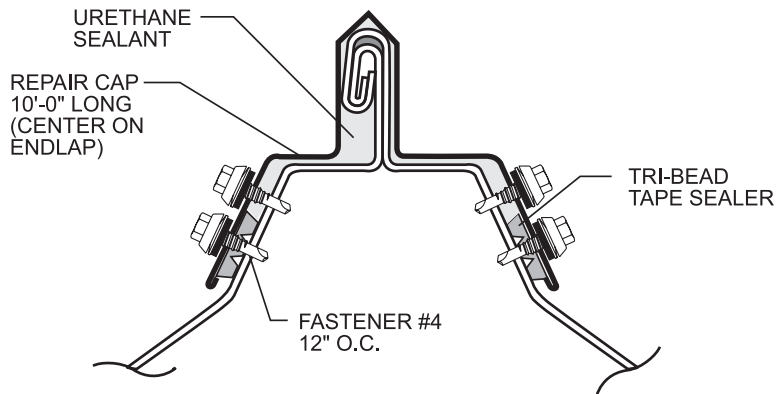

Check repair cap at each end to verify that urethane sealant has sealed across the entire cross section of the repair cap. Wipe off excess sealant.

TRIM DETAILS EAVE TO ENDLAP

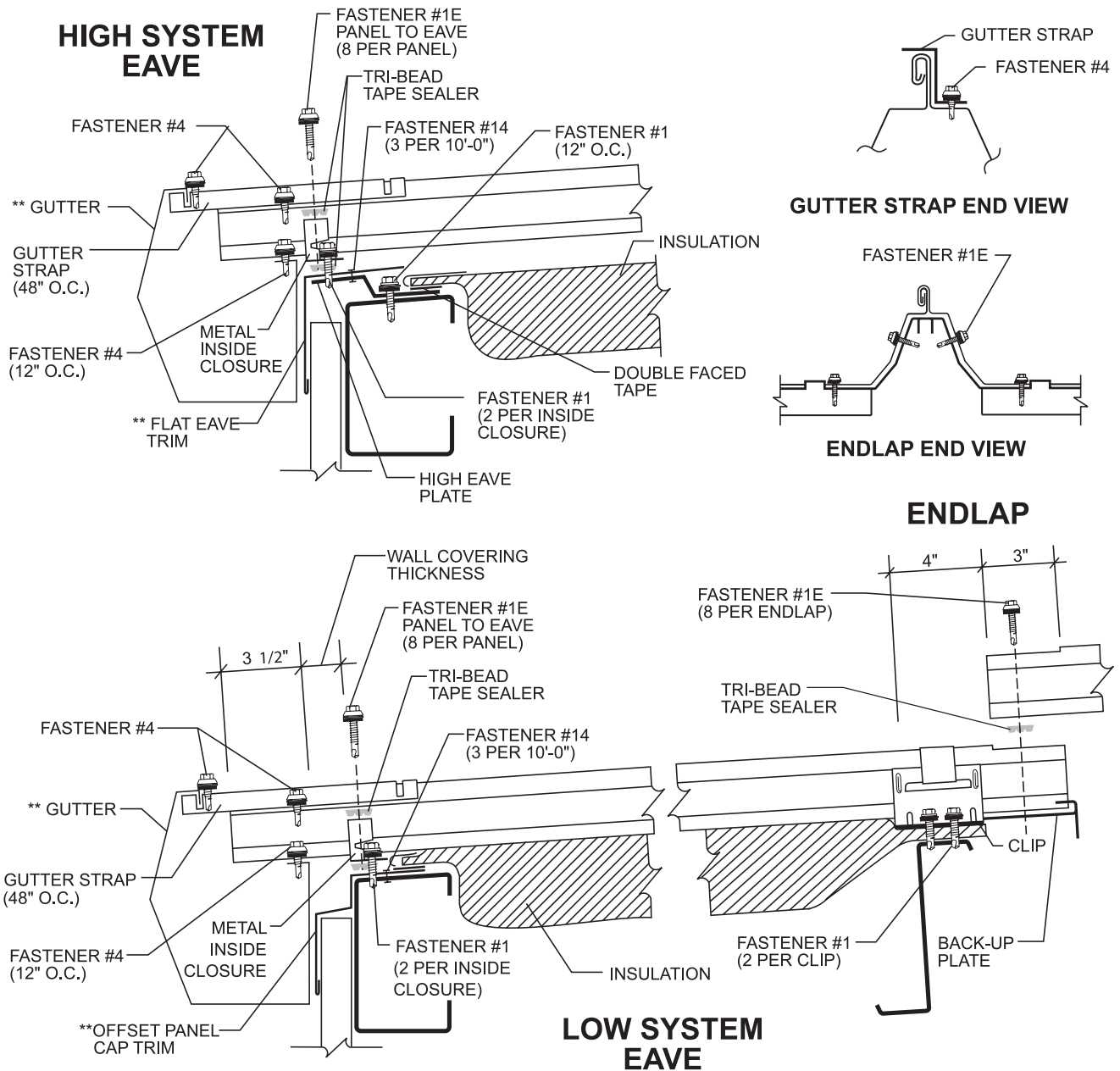

**Profile May Vary

NOTE: THE ABOVE GUTTER IS NOT DESIGNED TO RESIST THE IMPACT LOADS OF SLIDING ICE OR SNOW. IF ICE OR SNOW IS ANTICIPATED THEN USE THE SNOW GUTTER SHOWN ON PAGE 69, OR IF THE ABOVE GUTTER IS TO BE USED, IT MUST BE PROTECTED BY THE INSTALLATION OF A SNOW RETENTION DEVICE SUCH AS: S-5™ SnoFence™, SnoRail™, OR S-5™ ColorGard™.

SEE PRODUCT GUIDE FOR FASTENER SELECTION.

DESIGN

TRIM DETAILS RIDGE (12" PEAK PURLIN SPACING)

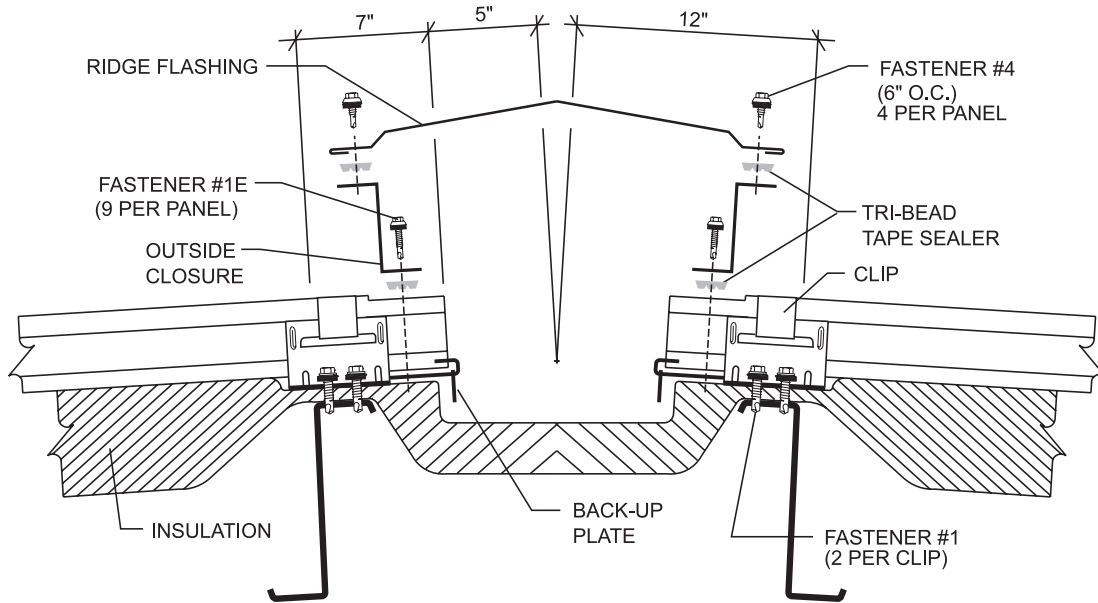

Install the ridge flashing starting and ending 1 1/4" plus endwall thickness outside the steel line. Fasten the ridge flashing to the outside closures with Fastener #4. Install a fastener 1 1/2" from panel seam on both sides of panel. Install additional fasteners directly above minor ribs of panel. Four fasteners are required at each panel. Leave 6" unfastened on each end to allow for the rake trim to be installed later. **DO NOT FASTEN THROUGH THE LOCK OF THE STANDING SEAM.**

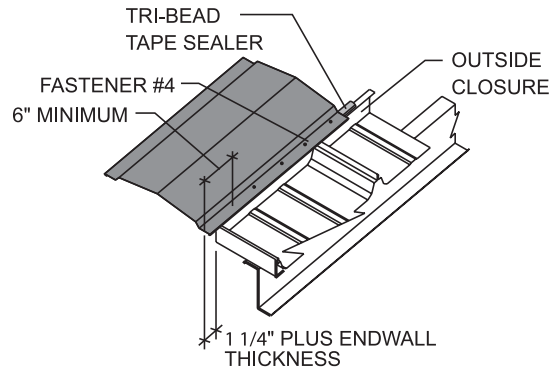
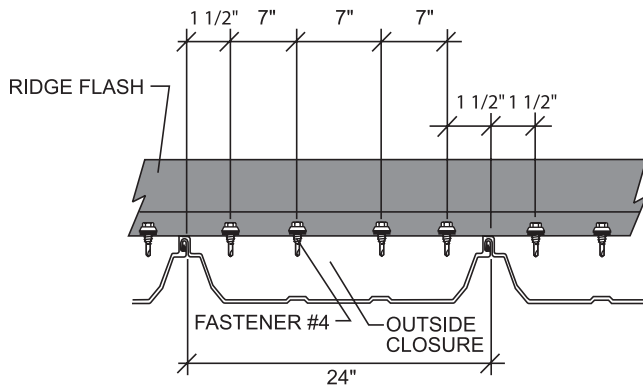

SEE PRODUCT GUIDE FOR FASTENER SELECTION.

TRIM DETAILS RIDGE (16" PEAK PURLIN SPACING)

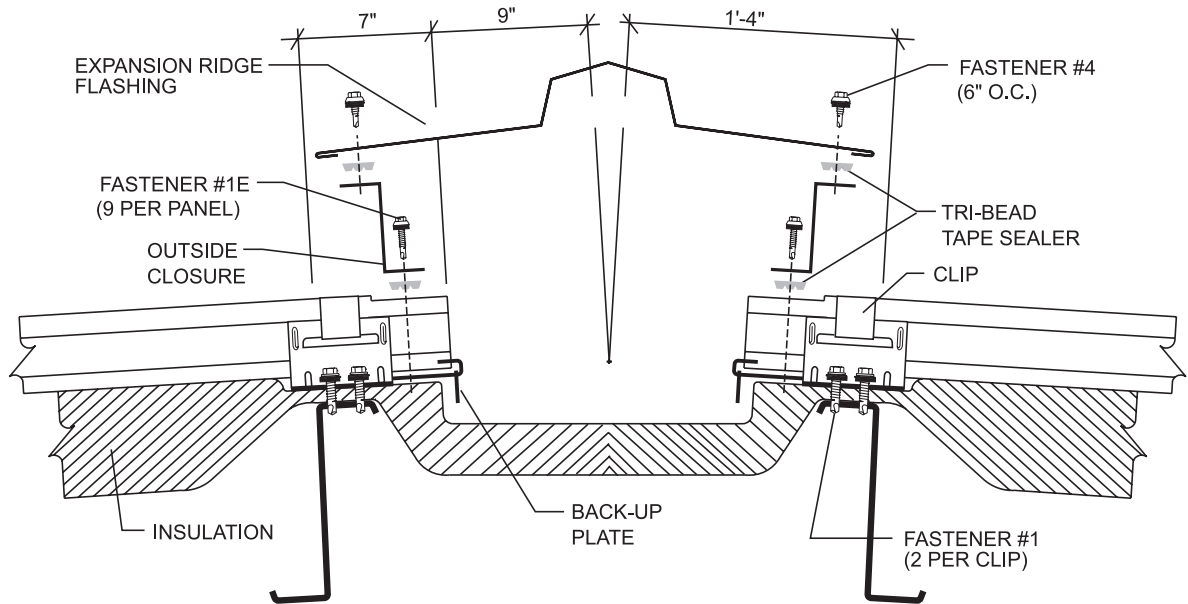

Install the ridge flashing starting and ending 1 1/4" plus endwall thickness outside the steel line. Fasten the ridge flashing to the outside closures with Fastener #4. Install a fastener 1 1/2" from panel seam on both sides of panel. Install additional fasteners directly above minor ribs of panel. Four fasteners are required at each panel. Leave 6" unfastened on each end to allow for the rake trim to be installed later. **DO NOT FASTEN THROUGH THE LOCK OF THE STANDING SEAM.**

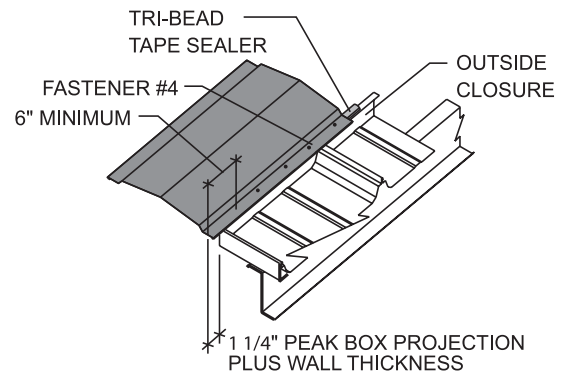
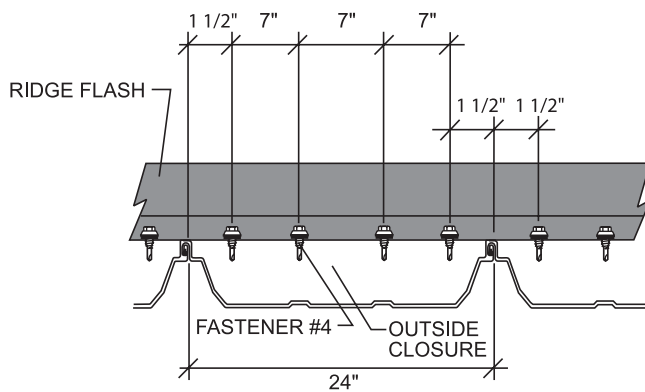

SEE PRODUCT GUIDE FOR FASTENER SELECTION.

DESIGN

TRIM DETAILS EXPANSION RIDGE FLASHING LAP

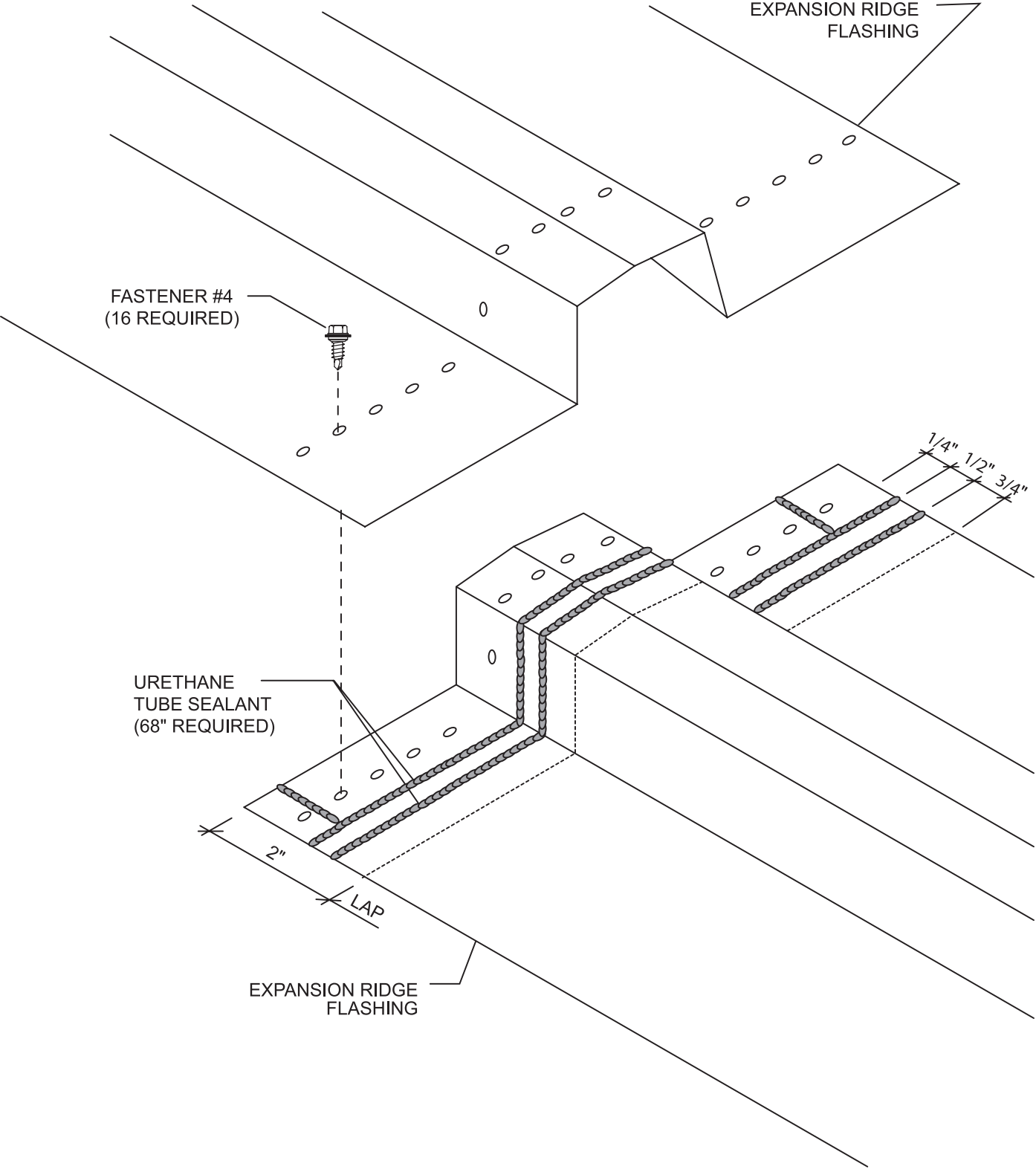

TRIM DETAILS RIDGE FLASHING LAP (Required At 200'-0 Intervals)

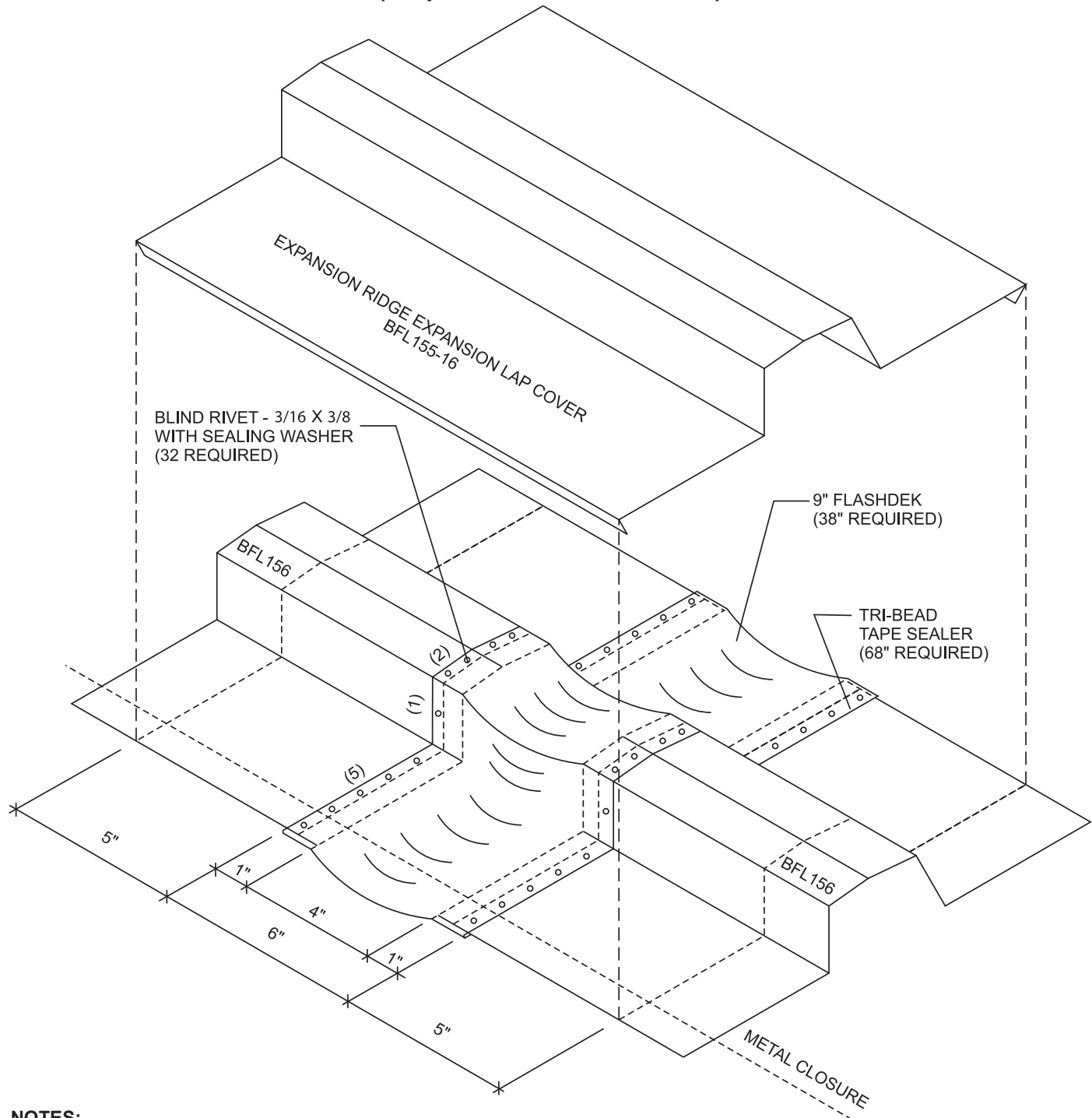

NOTES:

Fold the edge of the FLASHDEK over the BFL156 making sure that the end of the FLASHDEK is past the uphill edge of the metal outside closure. Do not fasten the Expansion Lap Cover BFL155-16 down to the Expansion Ridge. Use duck-bill pliers to crimp the flange of the Expansion Lap Cover over the Expansion Ridge trim.

DESIGN

TRIM DETAILS STANDARD GUTTER EXPANSION LAP DETAIL PROFILE MAY VARY (Required At 200'-0 Intervals)

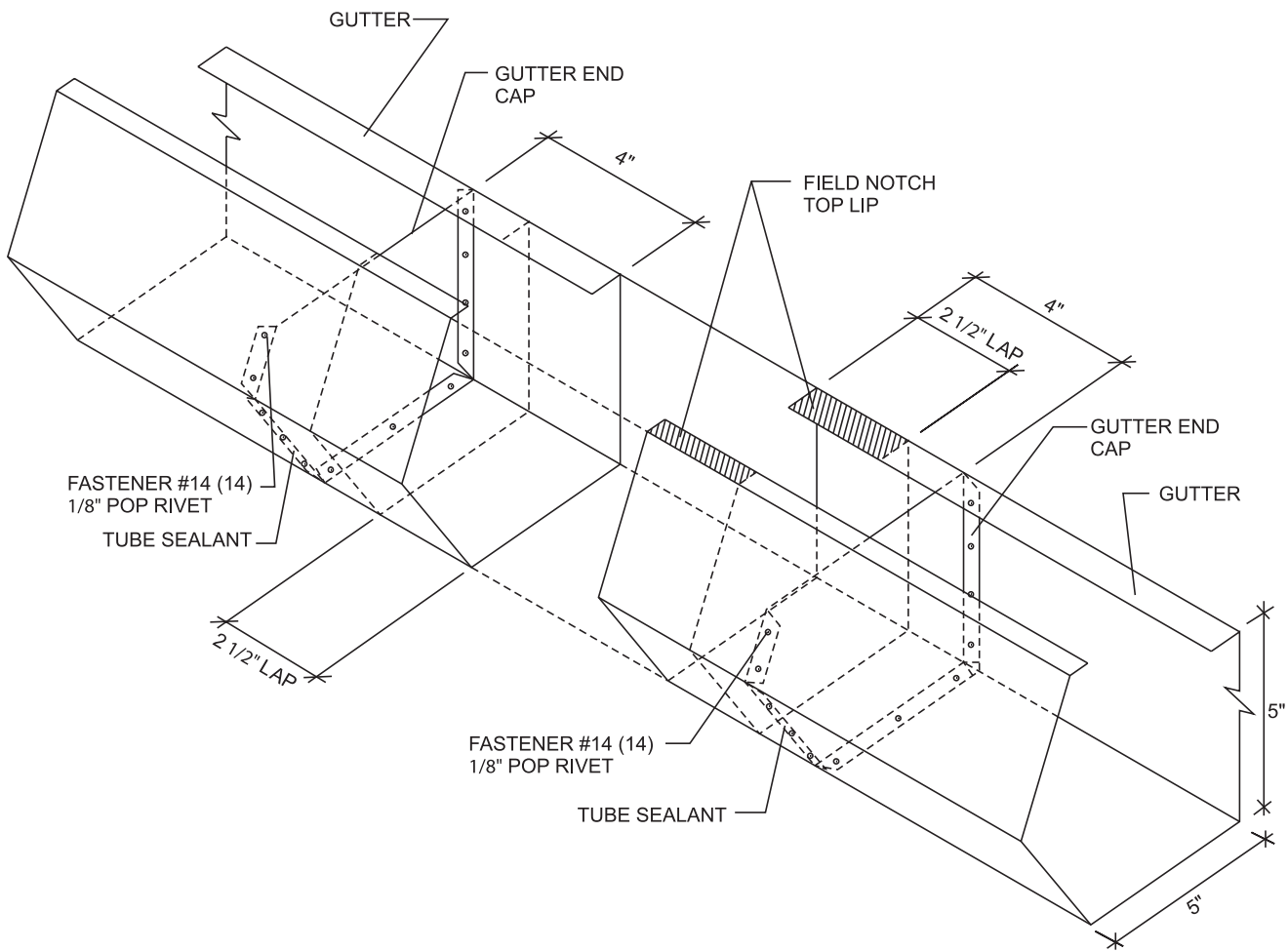

NOTES:

1. Install Gutter End Caps with Tube Sealant as shown.
2. Notch Gutter Lips as shown.
3. Insert Right Gutter into Left Gutter. Do Not Attach the Left and Right Gutters together.

TRIM DETAILS EXPANSION END CAP ASSEMBLY

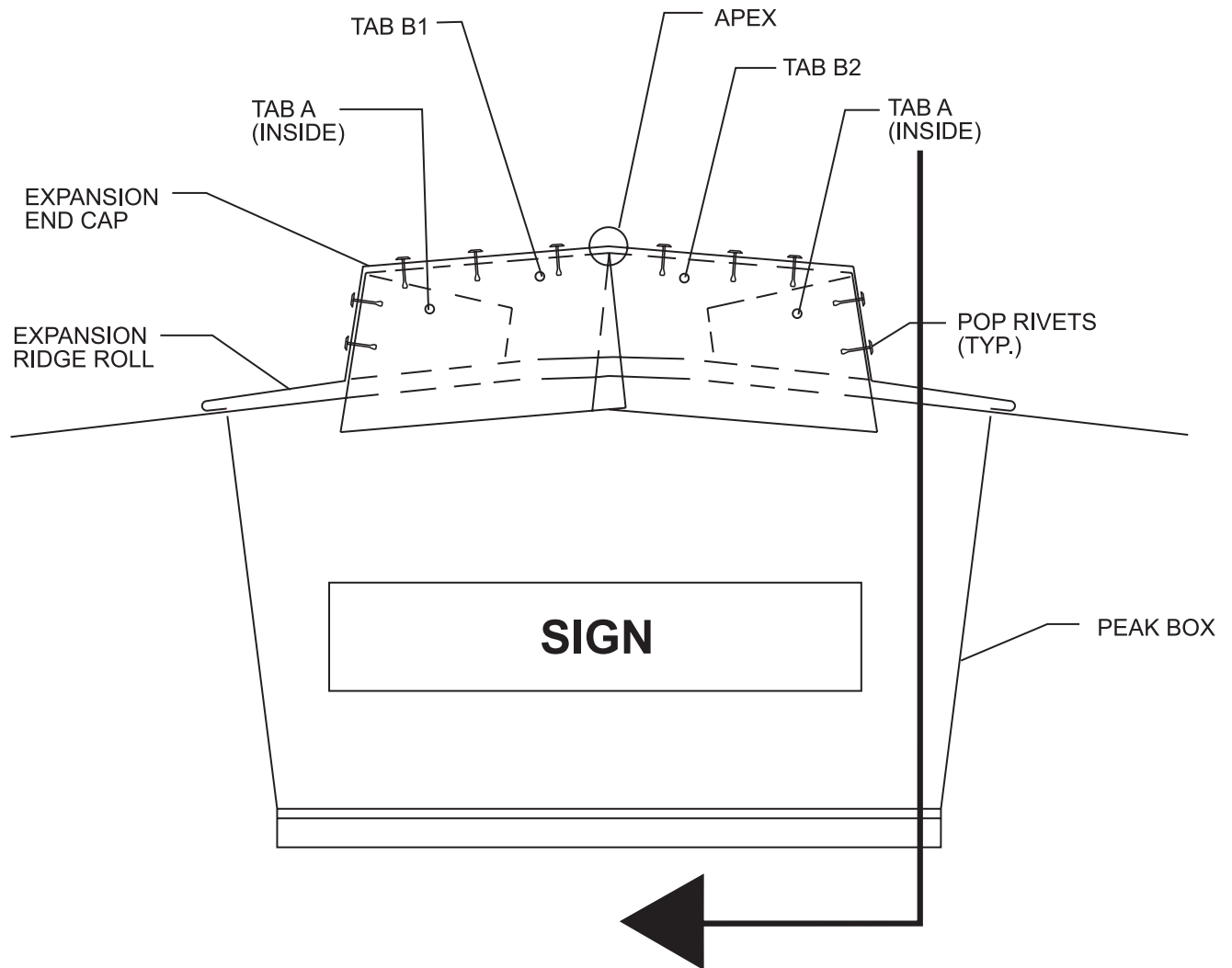

NOTES:

1. Apply 2 runs of tube sealant along vertical and horizontal surfaces of expansion ridge roll.
2. Place end cap over expansion ridge roll, allowing the end cap to conform to the ridge roll profile. Do not deform the top of the ridge roll by exerting too much pressure.
3. Make sure tab a is even with but not resting on top of the peak box. Tab a must be able to pivot in front of the peak box because of panel contraction.
4. Using a screwdriver, insert the blade in the apex of tab B1 and B2 and twist the blade enough to cause tab b1 to spread slightly away from tab B2.
5. Insert 10 pop rivets into the ridge roll as picture above.
6. Apply additional tube sealant along the edge of the end cap and smooth with finger.

DESIGN

TRIM DETAILS EXPANSION RIDGE END CAP

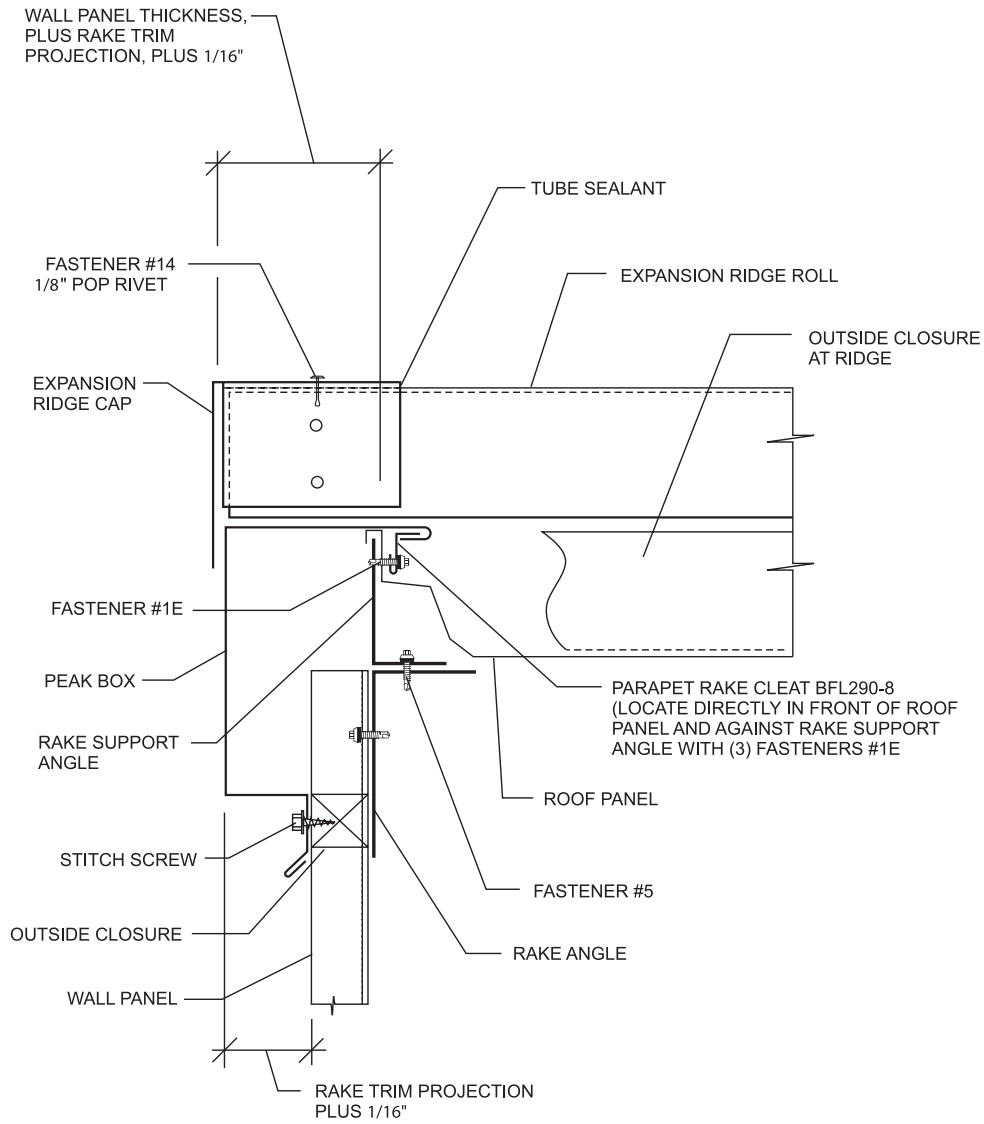

SECTION

TRIM DETAILS
FLOATING PEAK BOX

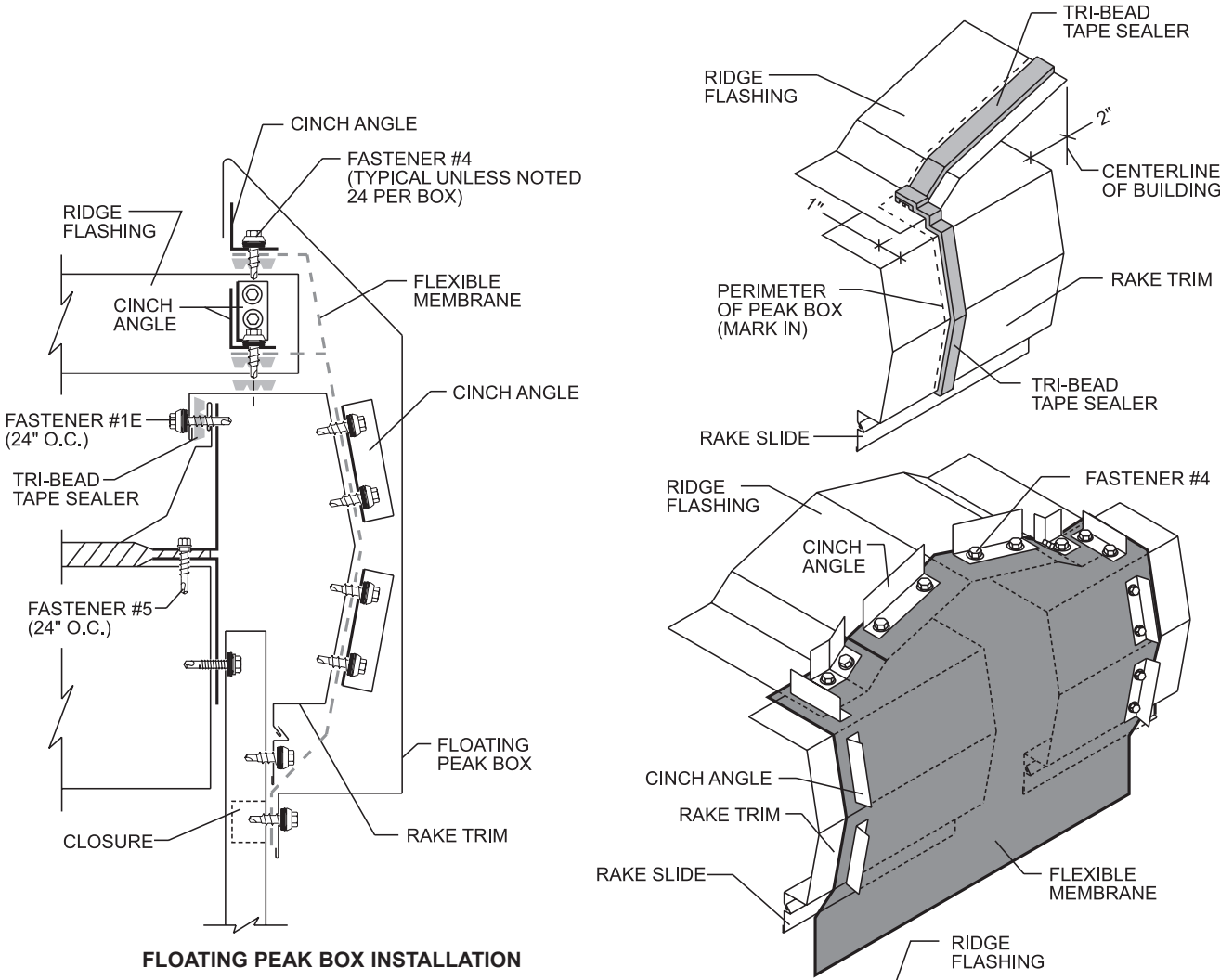

FLOATING PEAK BOX INSTALLATION

1. Install rake trim on each side of ridge to within 2" of centerline of building.
2. Install ridge flash so that it is on top leg of rake trim, 1" back from outside edge.
3. Temporarily set peak box in place and mark perimeter of box on rake trim and ridge flash. Remove peak box.
4. Just inside mark, install tape sealer continuously across ridge flash, then down the face of rake trim on both sides of ridge.
5. Place flexible membrane over tape sealer and hold in place with cinch angles. Cinch angles should be attached with Fastener #4. To prevent leaks, flexible membrane should be tight against ridge flash and rake trim with no wrinkles at the sealed edges.
6. Hook top of peak box over cinch angles installed on top of ridge flash and attach bottom of peak box to endwall with Fastener #4.

DESIGN

TRIM DETAILS RAKE

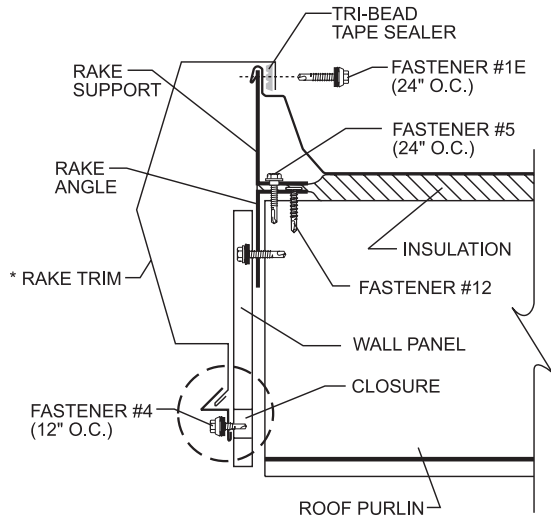

BEGINNING RAKE TRIM

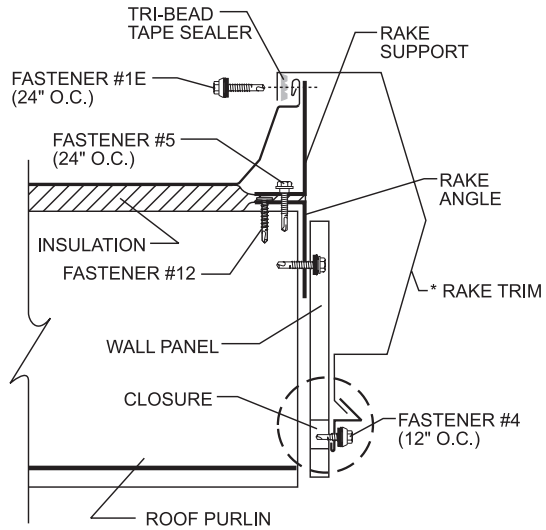

**TERMINATION RAKE TRIM
ON MODULE**



RAKE SLIDE
(FOR FLOATING SYSTEMS ONLY)

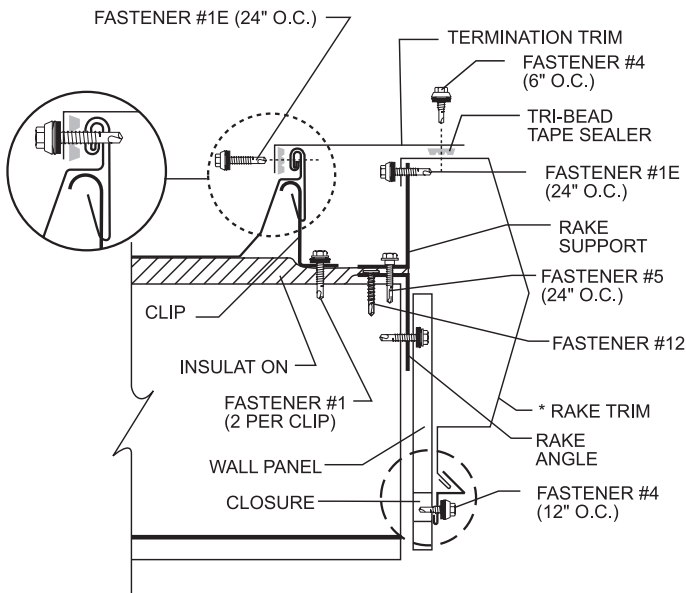

**TERMINATION RAKE TRIM
OFF MODULE**

*Profile May Vary

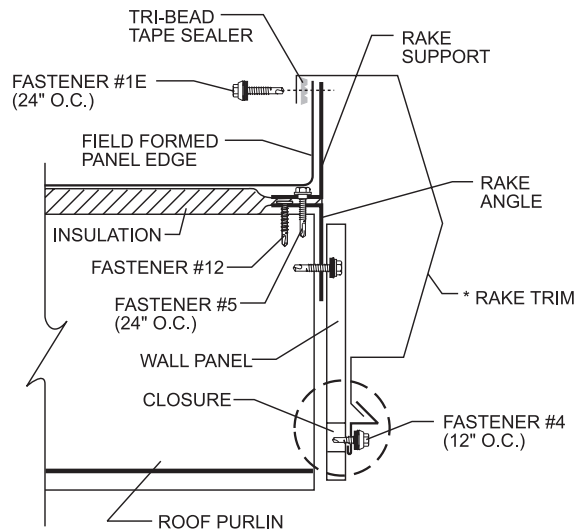

**TERMINATION RAKE TRIM
OFF MODULE (OPTIONAL)**

SEE PRODUCT GUIDE FOR FASTENER SELECTION.

TRIM DETAILS RAKE TO RAKE

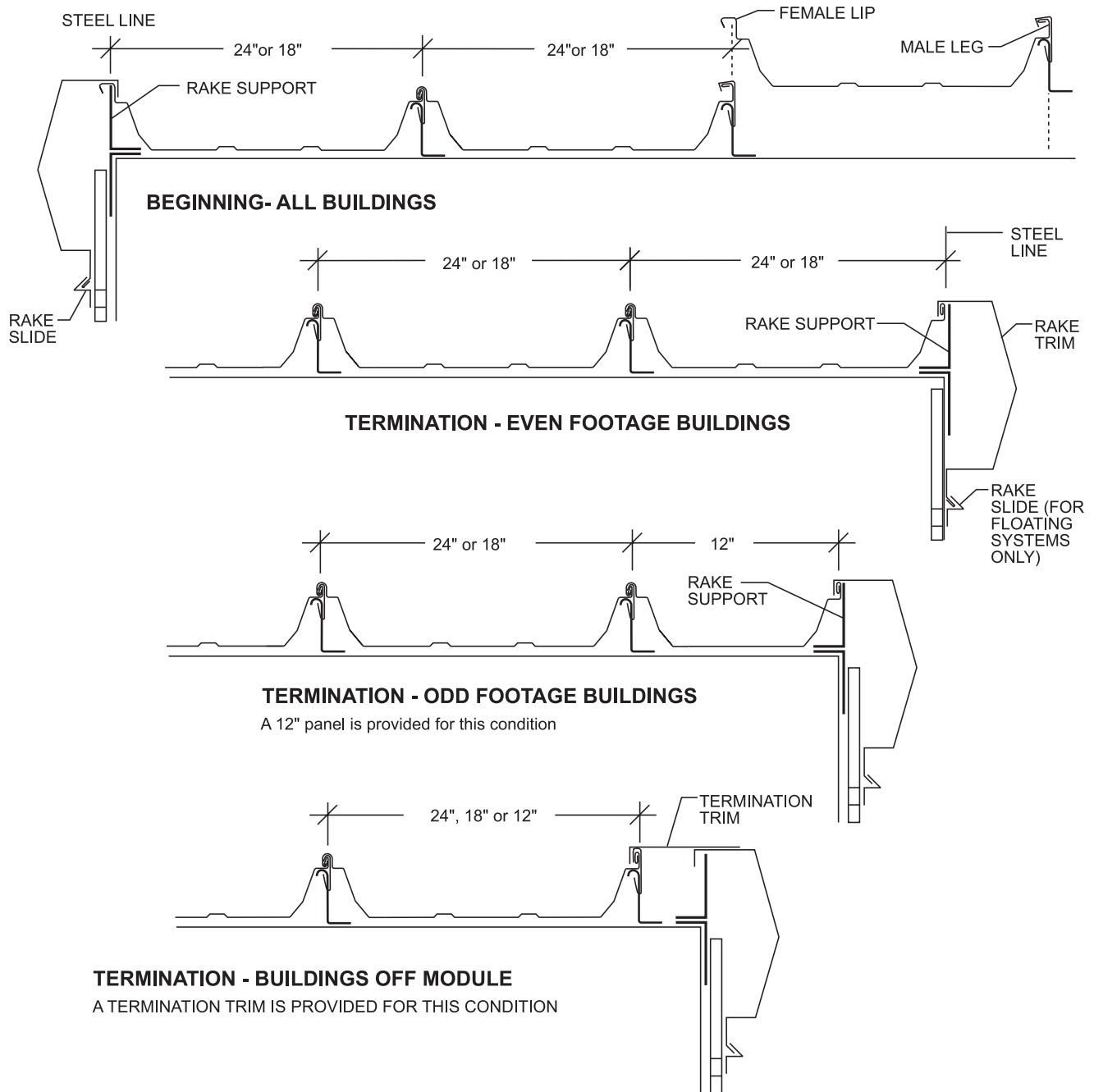

DESIGN

TRIM DETAILS RAKE PARAPET

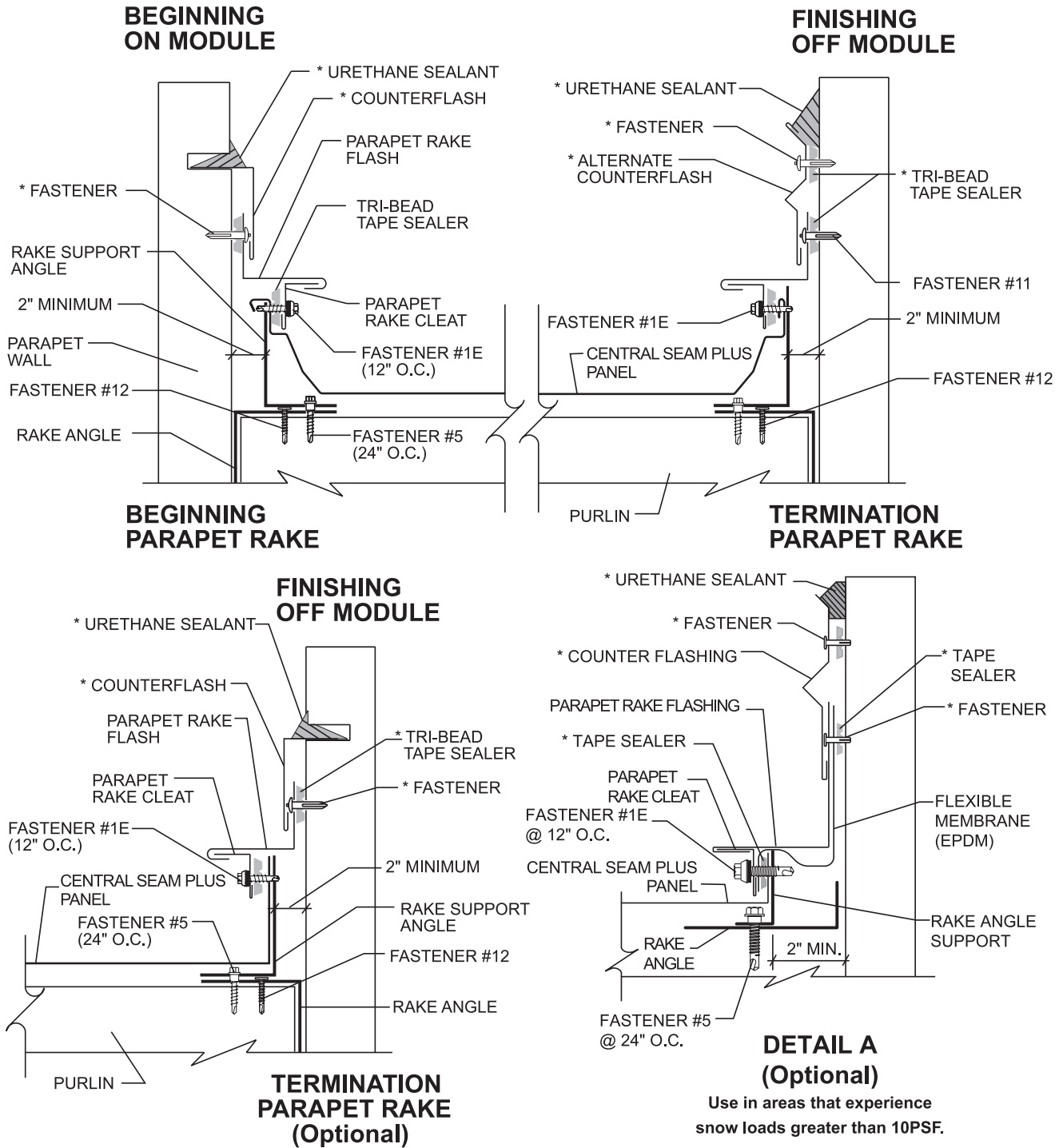

*Not by Building Manufacturer

TRIM DETAILS HIGH EAVE PARAPET

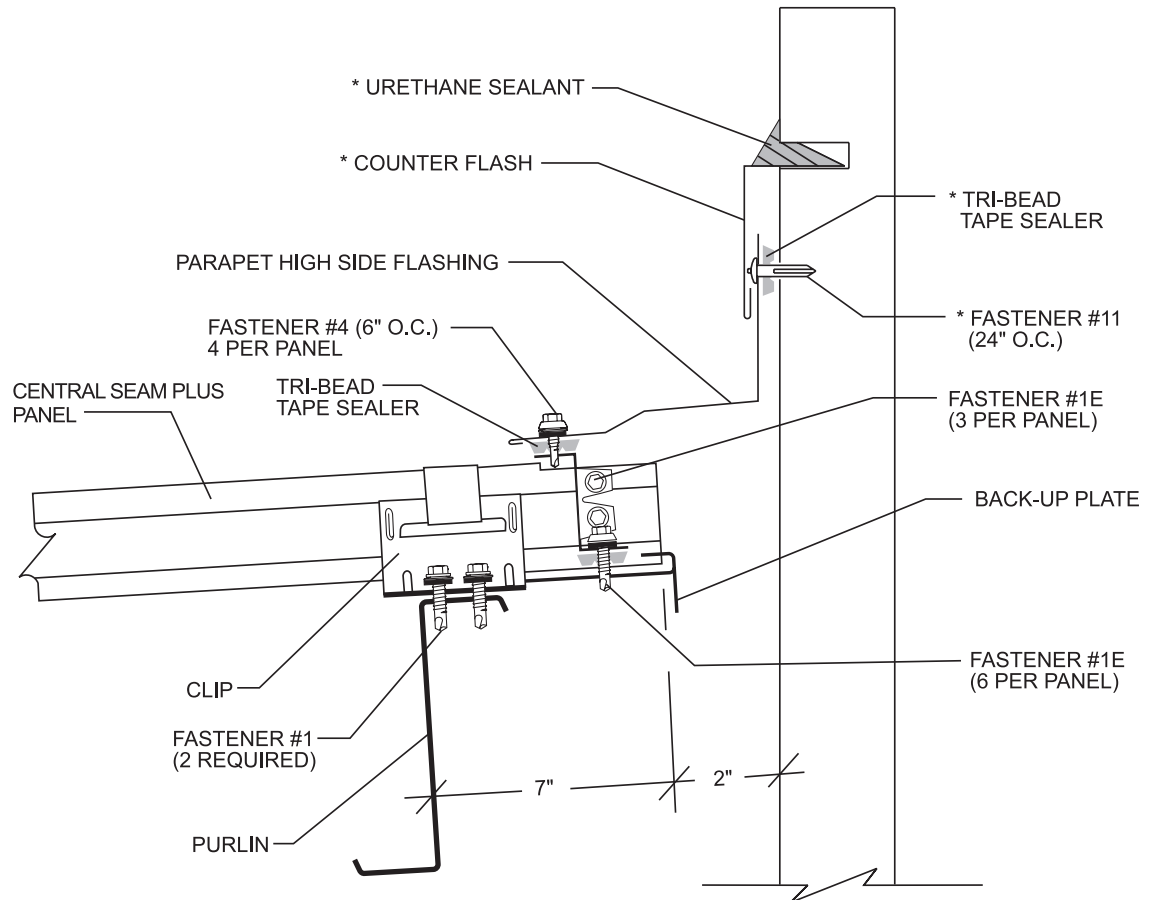

*Not by Building Manufacturer

NOTE: HIGH SIDE PURLIN IS 9" DOWN SLOPE

ERECTION SEQUENCE

TRIM DETAILS

EAVE

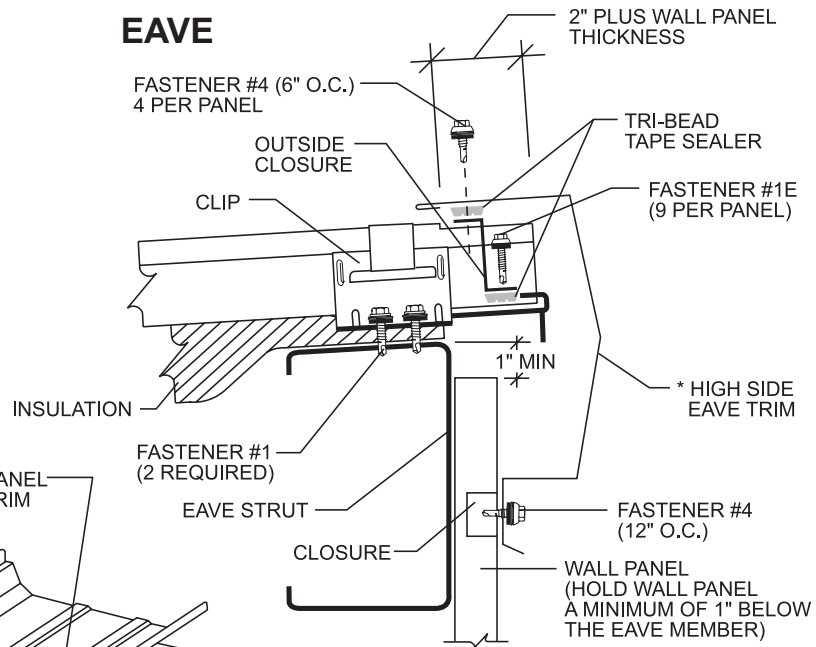

HIGH EAVE

NOTE
Top leg dimension of high side eave trim may have to be increased to accommodate wall thickness.

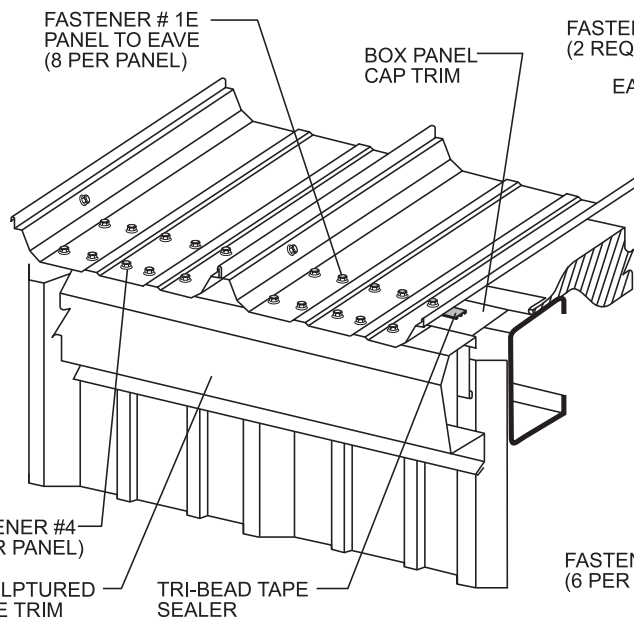
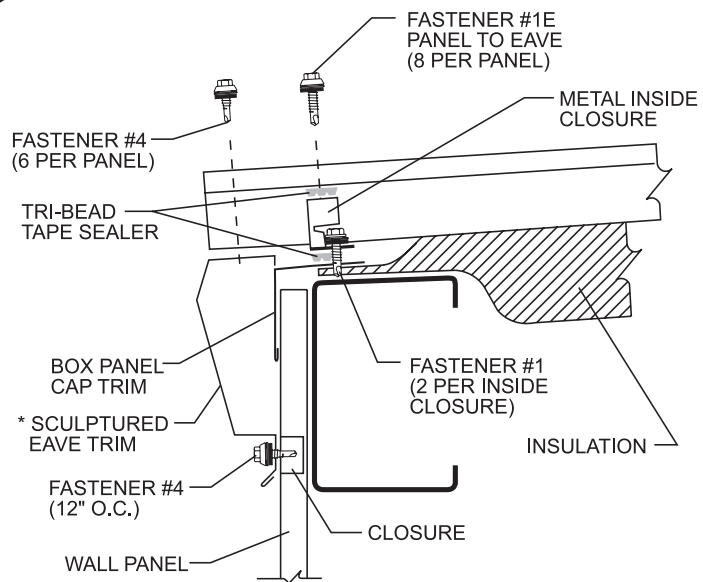

LOW EAVE WITH SCULPTURED EAVE TRIM

*Profile May Vary

NOTE: THIS OPTIONAL SCULPTURED EAVE TRIM IS AVAILABLE. HOWEVER, UNDER CERTAIN CONDITIONS IT MAY INDUCE STAINING OF WALL PANELS.

TRIM DETAILS SNOW GUTTER

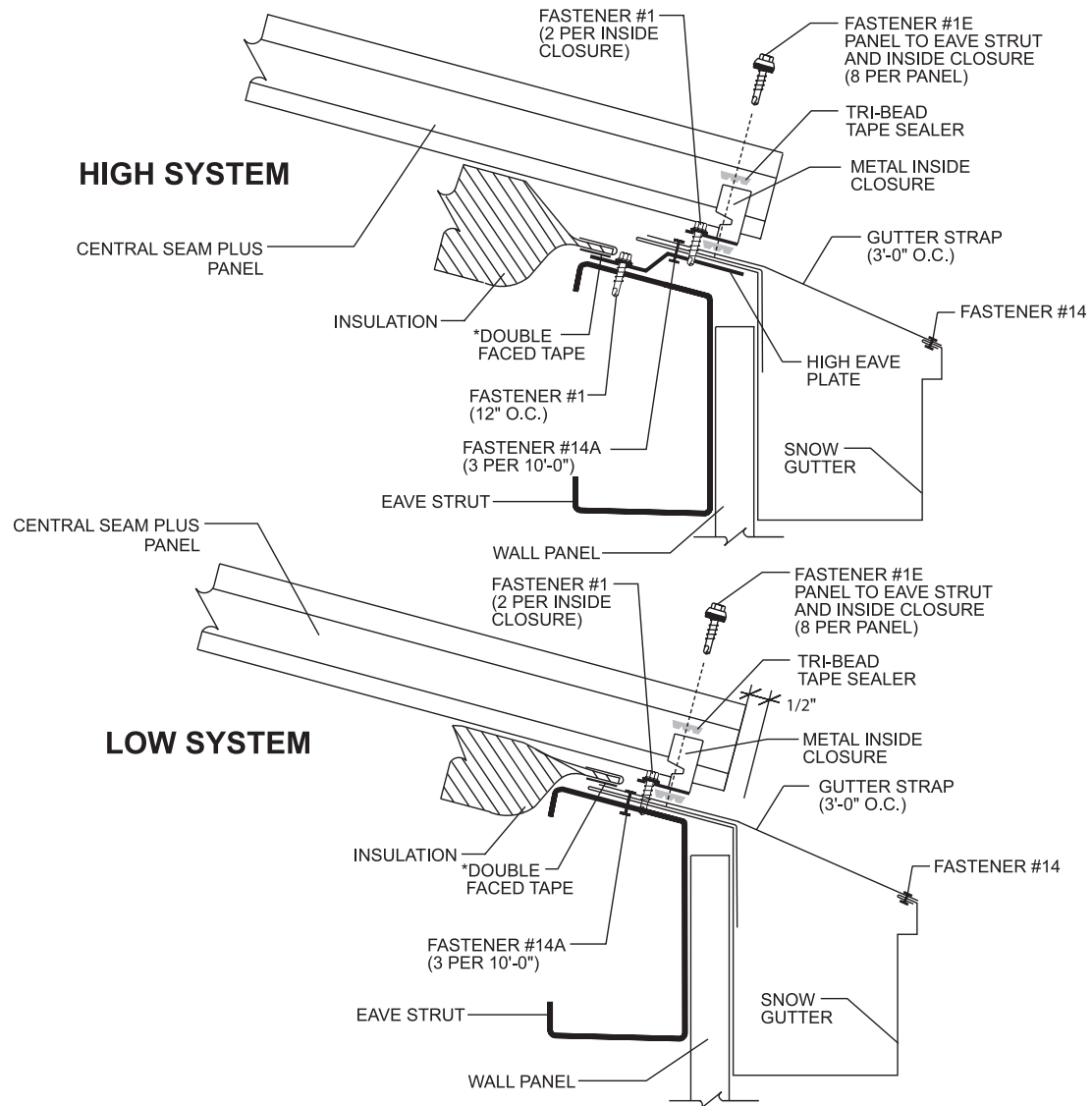

*Not by Building Manufacturer

NOTES:

1. Attach gutter to eave plate with Fastener #14A (3 fasteners per 10' piece).
2. Install gutter straps 3'-0" O.C.
3. Apply Tri-Bead tape sealer to slope leg of gutter.
4. Use minor rib tape sealer to fill voids in panel at minor ribs as shown on page 23.
5. Install panel with Fastener #1E at prepunched holes. **Panel must not overhang into gutter.**
6. Front top edge of gutter must not project above the plane of the panel pan.
7. Gutter may not catch all water during heavy rains.

DESIGN

TRIM DETAILS 10" DEEP GUTTER - FIXED EAVE

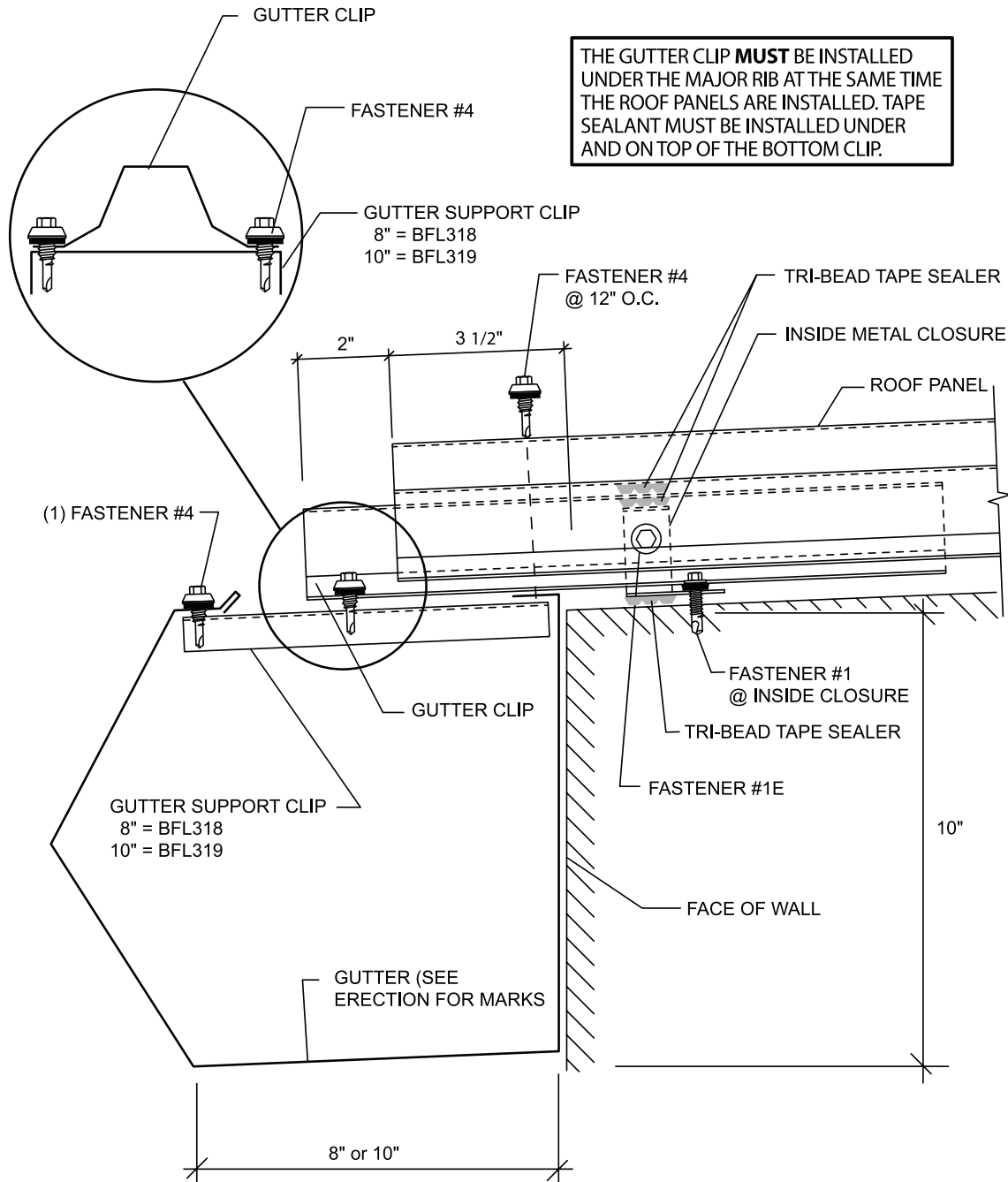

NOTE: Gutter may not catch all water during heavy rains.

TRIM DETAILS 10" DEEP GUTTER - EXPANSION EAVE

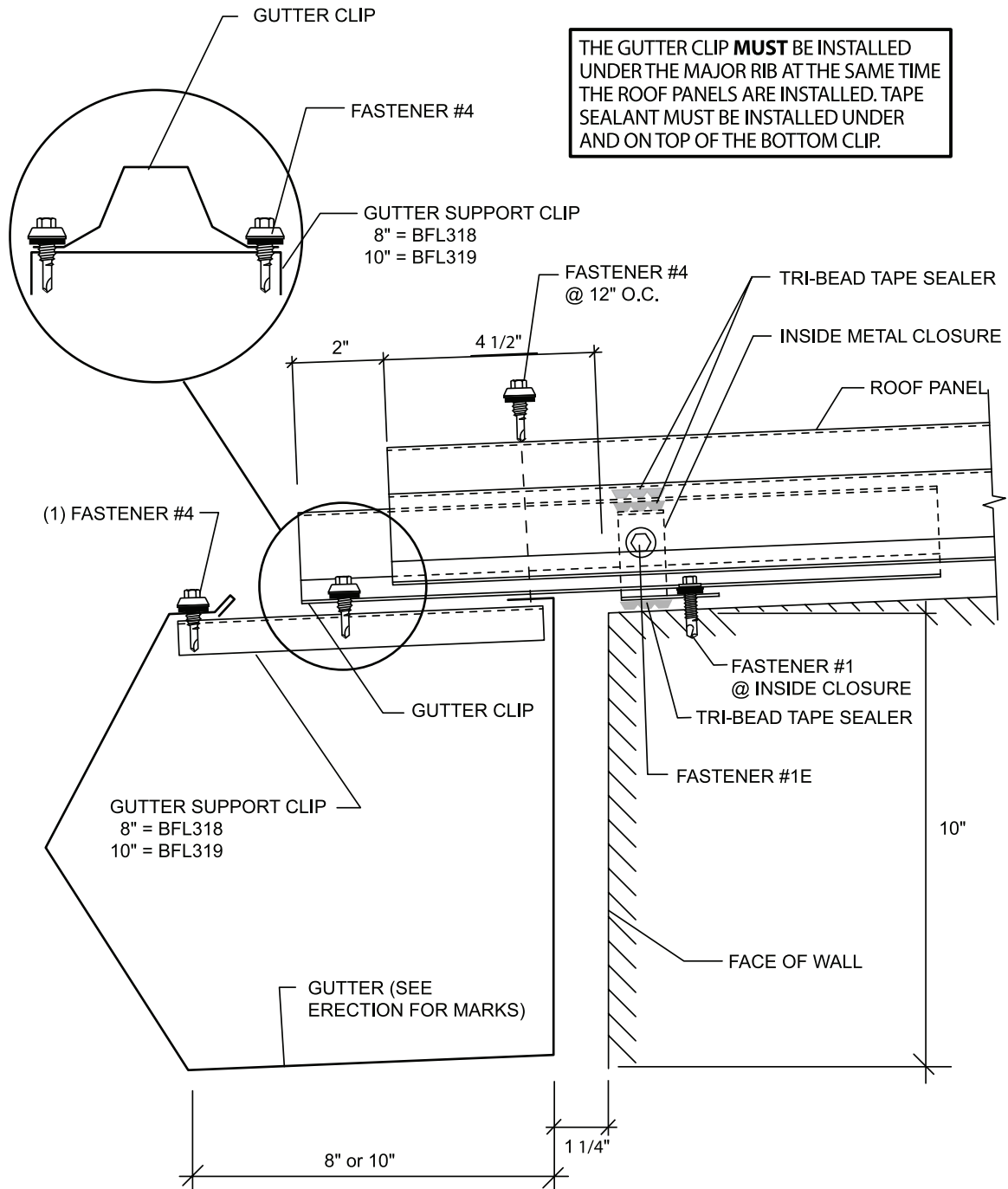

NOTE: Gutter may not catch all water during heavy rains.

DESIGN

TRIM DETAILS FLOATING HIP

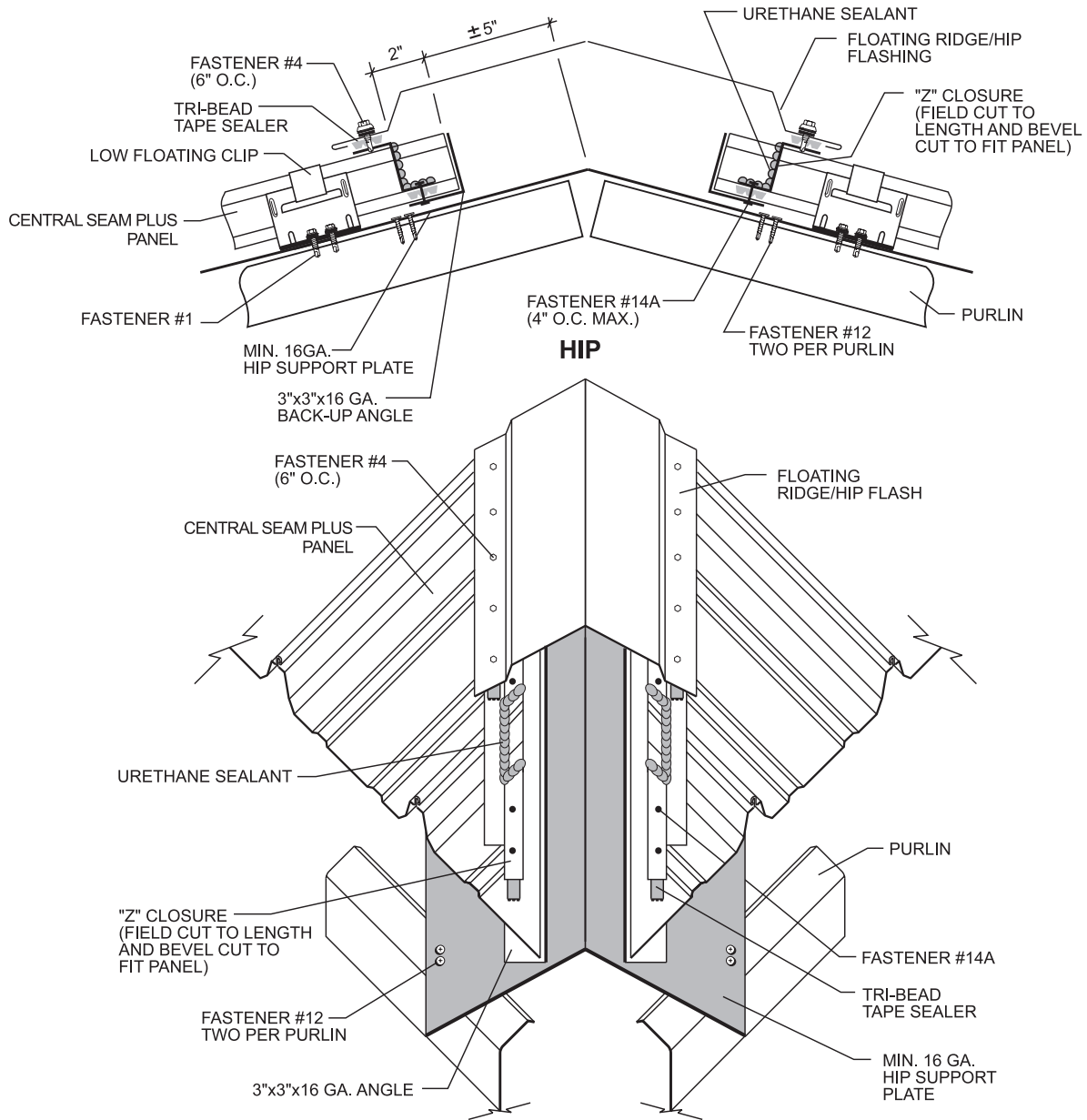

CAUTION

All trapezoidal panels are extremely difficult to install at hips and valleys in a weathertight manner. The use of these details should only be attempted by installation crews that are highly experienced. In order to assure weathertightness, the manufacturer recommends one of its vertical leg standing seam systems for use on roofs that require hips and valleys.

TRIM DETAILS VALLEY

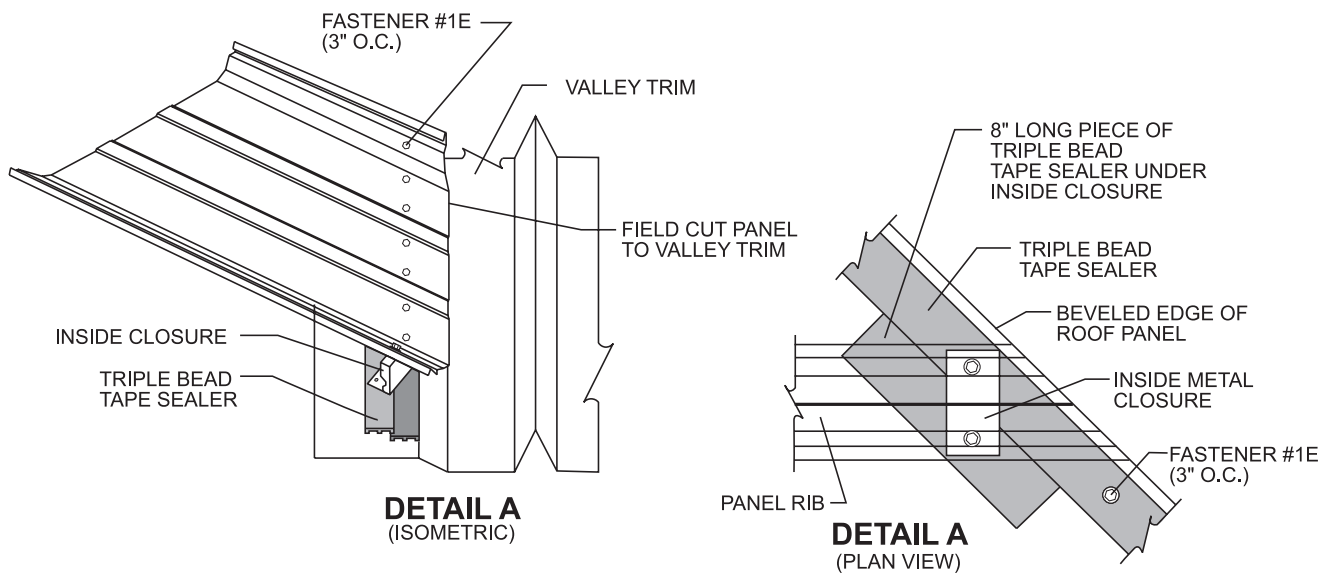
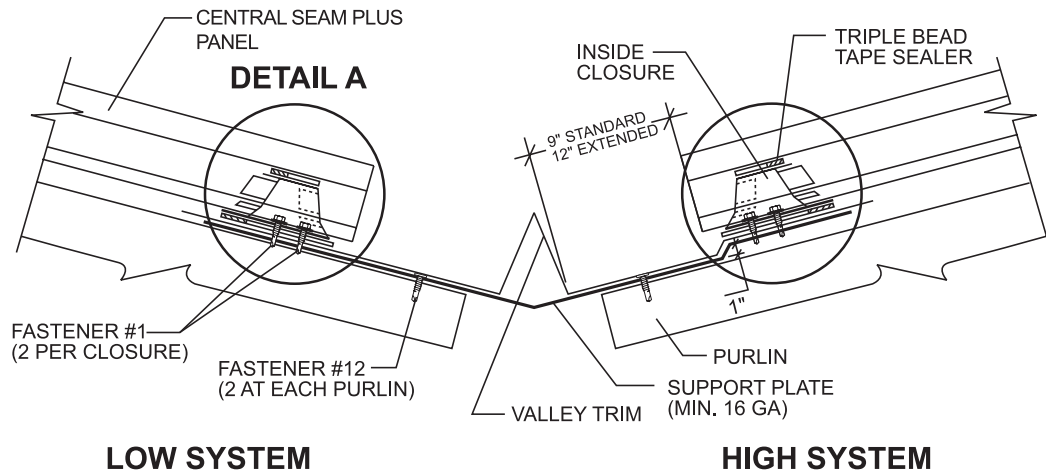

CAUTION

All trapezoidal panels are extremely difficult to install at hips and valleys in a weathertight manner. The use of these details should only be attempted by installation crews that are highly experienced. In order to assure weathertightness, the manufacturer recommends one of its vertical leg standing seam systems for use on roofs that require hips and valleys.

NOTES:



Right.
On Time.
Every Time.®

www.centralstatesco.com